

# Dragon Lady



**.60 - 1.20 Size  
Sport-Aerobatic A.R.F.**

## INSTRUCTIONS FOR FINAL ASSEMBLY

The Modeltech Dragon Lady 60 ARF is distributed exclusively by Global Hobby Distributors 18480 Bandilier Circle, Fountain Valley, CA 92708



All contents copyright © 2003, Global Hobby Distributors Version V2.0 April 2003

**Kit Product Number 123761**

### Specifications:

- **Wing Span:** 66 Inches
- **Wing Area:** 872 Square Inches
- **Length:** 55 Inches
- **Weight RTF:** 6 - 6.75 Pounds
- **Functions:** Ailerons, Elevator, Rudder and Throttle
- **Power:** .61 - 1.08 2-Stroke or .91 - 1.20 4-stroke
- **Radio:** 4 Channel w/4 Standard Servos

## TABLE OF CONTENTS

---

Safety Warning .....	2
Introduction .....	3
Section 1: Our Recommendations .....	4
Section 2: Tools and Supplies Required .....	5
Section 3: Kit Contents .....	5
Section 4: Metric Conversion Chart .....	6
Section 5: Replacement Parts .....	7
Section 6: A Note About Covering .....	7
Section 7: Wing Assembly .....	8
Section 8: Wing Mounting .....	10
Section 9: Stabilizer Installation .....	12
Section 10: Control Surface Hinging .....	15
Section 11: Tail Wheel Installation .....	17
Section 12: Main Landing Gear Installation .....	18
Section 13: Engine Installation .....	21
Section 14: Fuel Tank Assembly & Installation .....	24
Section 15: Servo Installation .....	26
Section 16: Throttle Linkage Installation .....	27
Section 17: Elevator & Rudder Control System Installation .....	29
Section 18: Aileron Control System Installation .....	31
Section 19: Cowling Installation .....	32
Section 20: Final Assembly .....	34
Section 21: Balancing the Dragon Lady 60 ARF .....	35
Section 22: Lateral Balancing the Dragon Lady 60 ARF .....	36
Section 23: Control Throws .....	36
Section 24: Preflight Check & Safety .....	37
Section 25: Flying the Dragon Lady 60 ARF .....	38
Section 26: Dragon Lady 60 ARF Trimming Chart .....	39
Section 27: Optional Rear-Mounted Elevator & Rudder Servos .....	40
Product Evaluation Sheet .....	43

## SAFETY WARNING

---

This R/C airplane is not a toy! If misused or abused, it can cause serious bodily injury and/or damage to property. Fly only in open areas and preferably at a dedicated R/C flying site. We suggest having a qualified instructor carefully inspect your airplane before its first flight. Please carefully read and follow all instructions included with this airplane, your radio control system and any other components purchased separately.

## FOR YOUR INFORMATION

To make your modeling experience totally enjoyable, we recommend that you get experienced, knowledgeable help with assembly and during your first flights. Your local hobby shop has information about flying clubs in your area whose membership includes qualified instructors. If there is no hobby shop in your area, we recommend that you contact the AMA at the address below. They will be able to help you locate a flying field near you.

Academy of Model Aeronautics  
5151 East Memorial Drive  
Muncie IN 47302-9252  
(800) 435-9262  
[www.modelaircraft.org](http://www.modelaircraft.org)

**OUR GUARANTEE** Modeltech guarantees this kit to be free from defects in both material and workmanship, at the date of purchase. This does not cover any component parts damaged by use, misuse or modification. **In no case shall Modeltech's liability exceed the original cost of the purchased kit.**

In that Modeltech has no control over the final assembly or material used for final assembly, no liability shall be assumed for any damage resulting from the use by the user of the final user-assembled product. By the act of using the final user-assembled product, the user accepts all resulting liability.

## INTRODUCTION

Thank you for purchasing the Modeltech Dragon Lady 60 ARF. Before completing the final assembly of your new airplane, please carefully read through this instruction manual in its entirety. Doing so will ensure your success the first time around!

### Modeltech Dragon Lady 60 ARF Features:

- Completely Prebuilt from Balsa, Light Plywood and Foam
- Expertly Covered with Real Heat-Shrink, Iron-On Covering Material
- Prepainted Fiberglass Cowling
- Durable Aluminum Main Landing Gear
- Blow-Molded Wheel Pants
- Clear Windscreen
- Hardware Included - Wheels, Fuel Tank, Engine Mount, Pushrods, Etc.
- Fast & Easy Assembly - Over 60 High-Resolution Digital Photos to Guide You

This instruction manual is designed to guide you through the entire final assembly process of your new airplane in the least amount of time possible. Along the way you'll learn how to properly assemble your new airplane and also learn tips that will help you in the future. We have listed some of our recommendations below. Please read through them before beginning assembly.

- Please read through each step before beginning assembly. You should find the layout very complete and straightforward. Our goal is to guide you through assembly without any of the headaches and hassles that you might expect.
- There are check boxes next to each step. After you complete a step, check off the box. This will help prevent you from losing your place.
- Cover your work table with brown paper or a soft cloth, both to protect the table and to protect the parts.
- Keep a couple of small bowls or jars handy to put the small parts in after you open the accessory bags.
- We're all excited to get a new airplane in the air, but take your time. This will ensure you build a straight, strong and great flying airplane.
- If you come across this symbol , it means that this is an important point or an assembly hint.

#### Visit Our Website

<http://globalservices.globalhobby.com>

If you should find a part missing or damaged, or have any questions about assembly, please contact us at the address below:



**Global Services**  
**18480 Bandilier Circle**  
**Fountain Valley CA 92708**

**Phone: (714) 963-0329**

**Fax: (714) 964-6236**

**E-mail: [service@globalhobby.net](mailto:service@globalhobby.net)**

To serve your needs better, please include your email address with any correspondence you send to us. Your email address will be added to our Customer Service Database so you will automatically receive free updates and tech notices for your particular product. You will also receive repair status updates (if applicable) and other important information about your product as it becomes available.

#### IMPORTANT INFORMATION ABOUT YOUR EMAIL ADDRESS

Global Hobby Distributors will not disclose the information it collects to outside parties. Global Hobby Distributors does not sell, trade, or rent your personal information to others. Your privacy is important to us.

## SECTION 1: OUR RECOMMENDATIONS

---

This section describes our recommendations to help you in deciding which types of accessories to purchase for your new Modeltech Dragon Lady 60 ARF. These suggestions are not set in stone, but they should provide you with a good starting point.

### What Engine Should I Use?

The Dragon Lady 60 will accept a wide variety of engines, so which engine you choose really depends on how you want to fly the airplane. For general sport flying, a .61 two stroke or .91 four stroke would be an ideal choice. Either of these engines will provide good overall performance and will pull the airplane through most aerobatic maneuvers with ease. Both engines can be mounted sideways for starting convenience, but the .61 will require the use of an aftermarket Pitt's Style muffler because the stock muffler is too long. If you use a .91 four stroke you can use the engine's stock muffler.

For all-out aerobatics a .91 - 1.08 two stroke or a 1.20 four stroke would be a great choice. Either of these engines will provide an excellent power-to-weight ratio, resulting in nearly unlimited vertical performance. Both engines can be mounted sideways for starting convenience, but the .91 and 1.08 will require the use of an aftermarket Pitt's Style muffler. If you use a 1.20 four stroke you can use the engine's stock muffler. Because these engines are heavier and will make the Dragon Lady nose heavy in its standard configuration, we have provided you the option of mounting the elevator and rudder servos in the back of the fuselage to counteract the extra nose weight.

### What Servos Should I Use?

There really is no reason to go overboard on high-priced, ultra-precision servos. A good, standard, dual ball bearing servo with a minimum of 40 ounces of torque will work well on the flight-control surfaces and a standard bushing servo will be good for use on the throttle.

### What Else Do I Need?

The Dragon Lady 60 includes most of the hardware you'll need to finish the airplane. You will need a 2-3/4" spinner, some basic building materials, such as adhesives, protective foam rubber for your radio gear, and fuel tubing. If you're using a larger, heavier engine and decide to install your elevator and rudder servos in the back of the fuselage, you will also need two 24" servo extensions so the servo leads can reach the receiver. We've provided a list below of the items we used on the airplane shown in this instruction manual.

#### Here's a List of What We Used to Finish Our Dragon Lady 60 ARF:

QTY. 1	210756	Magnum XL .61ARNV 2-Stroke Engine
QTY. 1	280180	Magnum Pitt's Style Muffler for XL .61ARNV
QTY. 1	237155	Magnum 2-3/4" Chrome Spinner*
QTY. 3	444110	Cirrus CS-71 BB Standard Servos
QTY. 1	444107	Cirrus CS-71 Standard Servo
QTY. 1	608660	APC 12 x 6 Composite Propeller
QTY. 1	115493	Thunderbolt R/C Long Glow Plug
QTY. 1	237500	Magnum In-Cowl Fueling Valve
QTY. 1	115923	Global XX Silicon Fuel Tubing
QTY. 1	868638	Dubro 1/4" Protective Foam Rubber
QTY. 1	592659	Williams Bros. Sportsman Pilot (optional)

If you plan on using a 1.20 four stroke engine, we strongly suggest replacing the stock engine mounting beams with a stronger aluminum engine mount. The Magnum Adjustable Aluminum Engine Mount (part # 279950) would be a good choice.

**IMPORTANT** The part numbers listed for the Cirrus servos are compatible with Hitec and JR radio control systems. These items are also available with connectors that are compatible with Futaba and Airtronics radio control systems. \*Includes 5/16 - 24 shaft adapter.

## SECTION 2: TOOLS AND SUPPLIES REQUIRED

The tools and supplies listed below will be necessary to finish the final assembly of your Dragon Lady 60 ARF. We suggest having these items on-hand before beginning assembly.

- |                                                             |                                                                    |
|-------------------------------------------------------------|--------------------------------------------------------------------|
| <input type="checkbox"/> Kwik Bond Thin C/A # 887500        | <input type="checkbox"/> Electric Drill                            |
| <input type="checkbox"/> Kwik Bond Thick C/A # 887510       | <input type="checkbox"/> Assorted Drill Bits                       |
| <input type="checkbox"/> Kwik Bond 5 Minute Epoxy # 887560  | <input type="checkbox"/> Dubro T-Pins # 567685                     |
| <input type="checkbox"/> Kwik Bond 30 Minute Epoxy # 887565 | <input type="checkbox"/> Ernst Airplane Stand # 223977             |
| <input type="checkbox"/> Kwik Bond C/A Debonder # 887545    | <input type="checkbox"/> Rotary Tool w/Cutting Disc & Sanding Drum |
| <input type="checkbox"/> Pacer Z-42 Threadlocker # 339162   | <input type="checkbox"/> Ruler                                     |
| <input type="checkbox"/> # 1 Phillips Head Screwdriver      | <input type="checkbox"/> Pencil                                    |
| <input type="checkbox"/> # 2 Phillips Head Screwdriver      | <input type="checkbox"/> Waxed Paper                               |
| <input type="checkbox"/> Dubro 5mm Drill & Tap Set # 867235 | <input type="checkbox"/> Builder's Triangle                        |
| <input type="checkbox"/> 3mm Hex Wrench                     | <input type="checkbox"/> 220 Grit Sandpaper w/Sanding Block        |
| <input type="checkbox"/> Adjustable Wrench                  | <input type="checkbox"/> Masking Tape                              |
| <input type="checkbox"/> Wire Cutters                       | <input type="checkbox"/> Paper Towels                              |
| <input type="checkbox"/> Needle Nose Pliers                 | <input type="checkbox"/> Rubbing Alcohol                           |
| <input type="checkbox"/> Excel Modeling Knife # 692801      | <input type="checkbox"/> NHP Epoxy Mixing Sticks # 864204          |
| <input type="checkbox"/> Scissors                           | <input type="checkbox"/> NHP Epoxy Mixing Cups # 864205            |

## SECTION 3: KIT CONTENTS

We have organized the parts as they come out of the box for easier identification during assembly. Before you begin assembly, group the parts as we list them below. This will ensure that you have all of the parts before you begin assembly and it will also help you become familiar with each part. If you find any parts missing or damaged, please contact us using the information below:



**Global Services**  
18480 Bandilier Circle  
Fountain Valley CA 92708

**On the Web**  
<http://globalservices.globalhobby.com>

Phone: (714) 963-0329

Fax: (714) 964-6236

E-mail: [service@globalhobby.net](mailto:service@globalhobby.net)

### AIRFRAME ASSEMBLIES

- (1) Fuselage
- (1) Right Wing Panel w/Aileron
- (1) Left Wing Panel w/Aileron
- (1) Horizontal Stabilizer w/Elevator
- (1) Vertical Stabilizer w/Rudder

### THROTTLE CONTROL SYSTEM

- (1) 18-3/8" Pushrod Wire w/Z-Bend
- (1) Adjustable Servo Connector Assembly

### AILERON CONTROL SYSTEM

- (1) Plywood Aileron Servo Tray (W22)
- (2) 4-1/2" Threaded Wires w/90° Bend
- (2) Nylon Adjustable Control Horns
- (2) Nylon Clevises
- (2) Nylon 90° Snap Keepers
- (8) C/A Style Hinges

**Continued On Next Page**

### TAIL WHEEL ASSEMBLY

- (1) Nylon Tail Wheel Bracket
- (1) Nylon Tail Wheel Tiller Arm
- (1) Prebent Tail Wheel Wire
- (1) Tail Wheel
- (2) Wheel Collars w/Set Screws
- (1) Nylon Spacer
- (1) 2.5mm x 12mm Wood Screw
- (3) 3mm x 12mm Wood Screws

### ENGINE MOUNT ASSEMBLY

- (2) Engine Mounting Beams
- (4) 4mm x 20mm Socket-Cap Screws
- (4) 4mm x 30mm Socket-Cap Screws - Optional
- (4) 4mm Blind Nuts
- (4) 4mm x 25mm Socket-Cap Screws
- (4) 4mm Lock Nuts
- (12) 4mm Flat Washers

### ELEVATOR CONTROL SYSTEM

- (1) 31" Threaded Wire
- (1) Nylon Control Horn w/Backplate
- (2) 2mm x 20mm Machine Screws
- (1) Nylon Clevis
- (1) Nylon 90° Snap Keeper
- (6) C/A Style Hinges

### FUEL TANK ASSEMBLY

- (1) 360cc Fuel Tank
- (1) Large Diameter Metal Plate
- (1) Small Diameter Metal Plate
- (1) Rubber Stopper
- (1) Fuel Pick-Up "Clunk"
- (1) 3mm x 20mm Machine Screw
- (1) Silicon Fuel Tubing
- (2) Aluminum Tubing

### RUDDER CONTROL SYSTEM

- (1) 31" Threaded Wire
- (1) Nylon Control Horn w/Backplate
- (2) 2mm x 20mm Machine Screws
- (1) Nylon Clevis
- (1) Nylon 90° Snap Keeper
- (3) C/A Style Hinges

### LANDING GEAR ASSEMBLY

- (1) Prebent Aluminum Main Gear Strut
- (2) Blow-Molded Wheel Pants
- (2) Main Gear Wheels
- (2) Plywood Mounting Plates (D36)
- (2) 4mm Threaded Axles w/Lock Nuts
- (4) 4mm Wheel Collars w/Set Screws
- (4) 4mm x 20mm Machine Screws
- (4) 4mm Flat Washers
- (2) 3mm x 12mm Machine Screws
- (2) 3mm Blind Nuts

### MISCELLANEOUS WING PARTS

- (1) Hardwood Wing Joiner (W3)
- (2) 5mm x 40mm Machine Screws
- (2) 5mm Flat Washers
- (2) 5mm Blind Nuts - Optional

### MISCELLANEOUS FUSELAGE PARTS

- (1) Prepainted Fiberglass Cowling
- (1) Plywood Engine Mount Spacer (F1A) - Optional
- (1) Plywood Fuselage Servo Tray (D29)
- (1) Clear Plastic Windscreen
- (4) 3mm x 10mm Wood Screws
- (4) 3mm Flat Washers
- (2) 2mm x 6mm Wood Screws
- (1) Length of Clear Tubing
- (1) Decal Sheet

## SECTION 4: METRIC CONVERSION CHART

To convert inches into millimeters: Inches x 25.4 = mm To convert millimeters into inches: Millimeters / 25.4 = in

1/64"	=	.4mm	3/16"	=	4.8mm	1"	=	25.4mm	21"	=	533.4mm
1/32"	=	.8mm	1/4"	=	6.4mm	2"	=	50.8mm	24"	=	609.6mm
1/16"	=	1.6mm	3/8"	=	9.5mm	3"	=	76.2mm	30"	=	762.0mm
3/32"	=	2.4mm	1/2"	=	12.7mm	6"	=	152.4mm	36"	=	914.4mm
1/8"	=	3.2mm	5/8"	=	15.9mm	12"	=	304.8mm			
5/32"	=	4.0mm	3/4"	=	19.0mm	18"	=	457.2mm			

## SECTION 5: REPLACEMENT PARTS

---

Global stocks a complete line of replacement parts for your Modeltech Dragon Lady 60 ARF. Listed below are the replacement parts that are available along with their respective part numbers for easy ordering convenience. We suggest ordering directly from your local dealer. If your dealer does not stock Modeltech products, you can order directly from us at the address shown below:



**Global Services**  
18480 Bandilier Circle  
Fountain Valley CA 92708

**On the Web**  
<http://globalservices.globalhobby.com>

Phone: (714) 963-0329 Fax: (714) 964-6236

Modeltech Dragon Lady 60 - Complete	-	123761	Blow-Molded Wheel Pants	-	120086
Instruction Manual	-	120080	Engine Mount w/Hardware	-	120087
Wing Set	-	120081	Hardware Bag	-	120088
Fuselage Set	-	120082	360cc Fuel Tank Assembly	-	120074
Stabilizer Set	-	120083	Aluminum Landing Gear Strut	-	120089
Prepainted Fiberglass Cowling	-	120084	Tail Wheel Assembly	-	120076
Clear Windscreen	-	120085	Decal Sheet	-	120090

## SECTION 6: A NOTE ABOUT COVERING

---

The covering material used on the Dragon Lady 60 ARF is real iron-on, heat-shrink covering material, not cheap "shelf paper." Because of this, it is possible with heat and humidity changes that the covering on your airplane may wrinkle or sag. This trait is inherent in all types of heat-shrink material. To remove any wrinkles that might be visible you will need to purchase, or borrow from a fellow modeler, a heat iron. If you need to purchase one, the **Global Heat Sealing Iron # 360900** is recommended.

**Follow this simple procedure to remove the wrinkles:**

- Plug in and turn on the sealing iron to the medium-high temperature setting. Allow the iron to heat up for approximately 5 - 7 minutes.
  - After the iron has reached temperature, lightly apply the iron to the wrinkled section of the covering. Move the iron slowly over the wrinkled section until the covering tightens and the wrinkles disappear. You will notice that the color of the covering will darken when it is heated. When the covering cools back down, it will return to its normal color.
- ☞ If the color layer smears from any of the seams the temperature of the iron is too hot. Turn the temperature dial down and wait about 5 minutes for the iron to adjust to the lower temperature. You can remove any excess color streaks using a paper towel soaked with a small quantity of Acetone.

### WARNING

**We do not suggest storing your airplane in an extremely hot environment (like the back of your car in direct sunlight) for any length of time. The extreme heat could cause the covering material to wrinkle or sag and possibly damage the clear windscreen, and the fragile components of the radio system.**

## SECTION 7: WING ASSEMBLY

### YOU'LL NEED THE FOLLOWING PARTS FROM THE KIT:

- (1) Right Wing Panel w/Aileron
- (1) Left Wing Panel w/Aileron
- (1) Hardwood Wing Joiner (W3)

### YOU'LL NEED THE FOLLOWING TOOLS AND SUPPLIES:

- Kwik Bond 30 Minute Epoxy
- Excel Modeling Knife
- Ruler
- Pencil
- 220 Grit Sandpaper w/Sanding Block
- Masking Tape
- Paper Towels
- Rubbing Alcohol
- NHP Epoxy Mixing Sticks
- NHP Epoxy Mixing Cups

### Step 1: Installing the Wing Joiner

- Remove the aileron and hinges from each of the two wing panels and set them aside for now.

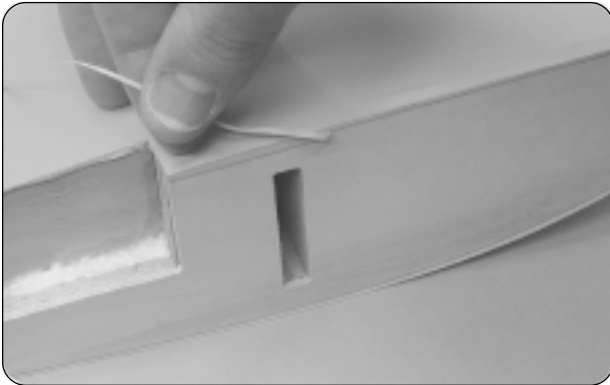

- Using a modeling knife, cut away and remove the excess covering material that overlaps onto the root ribs of each wing panel, leaving about 1/16" overlapped so it does not pull away.

**IMPORTANT** It's very important to the integrity of the wing center section joint that you remove as much covering material from the root ribs as possible.

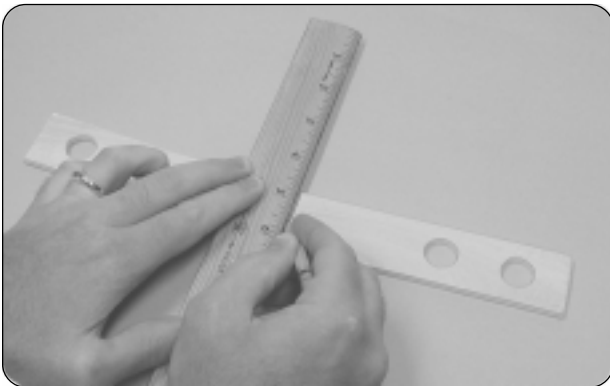

- Use a ruler and a pencil to locate and draw a vertical centerline on each side of the hardwood wing joiner.

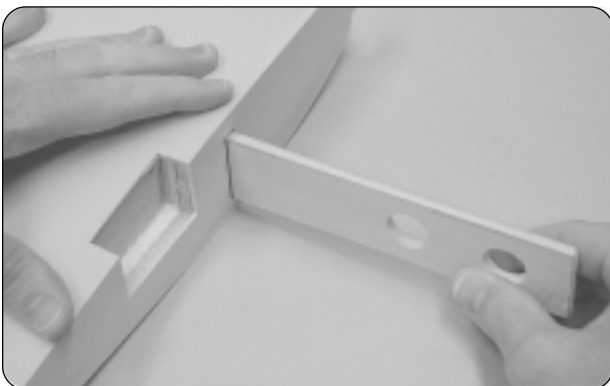

- Test-fit the wing joiner into each wing panel. It should slide easily into each panel up to the centerline you drew.

☞ If it does not fit properly, use 220 grit sandpaper with a sanding block to lightly sand the edges and tips of the joiner, until you are satisfied with the fit.

**IMPORTANT** The wing joiner is cut in a "V-shape." When test-fitting the joiner, make sure the v-shape is toward the **top** of the wing.

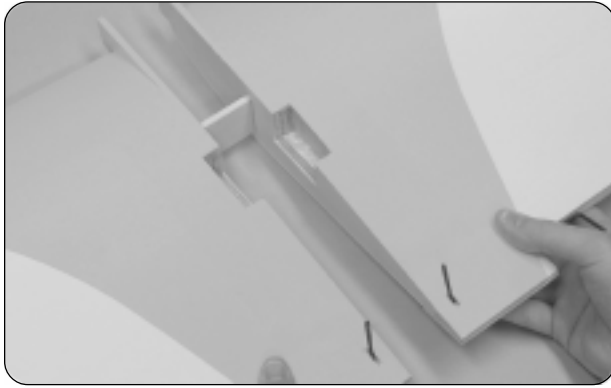

❑ Slide both wing panels together with the wing joiner temporarily installed (without using glue).

☞ Again, make sure the wing joiner's "V-shape" is toward the **top** of the wing panels. This will help ensure the proper dihedral angle.

❑ Look carefully at the center section joint: the wing panels should fit together tightly with few or no gaps in the joint.

☞ If the wing panels do not fit together properly, remove the wing joiner and use 220 grit sandpaper with a sanding block to lightly sand the edges and tips of the joiner, until you are satisfied with the fit.

❑ When satisfied with the fit, pull the wing panels apart and remove the wing joiner.

## Step 2: Joining the Wing Panels



❑ Apply a long strip of masking tape to the top and bottom edges of the root rib on each wing panel.

☞ The masking tape will prevent excess epoxy from getting onto the wing panels when you join them.

❑ Mix a generous amount of 30 minute epoxy. Working with only one wing panel for now, apply a thin layer of epoxy inside the wing joiner box and to only half of the wing joiner. Make sure to cover the top and bottom, as well as the sides, and use enough epoxy to fill any gaps.

❑ Slide the wing joiner into the wing panel up to its centerline. Quickly remove any excess epoxy using a paper towel and rubbing alcohol, and allow the epoxy to set up before proceeding.

❑ After the epoxy has set up, test-fit both wing panels together again to double-check that they still fit together properly. Check the leading and trailing edges, too. It's important that they be even with each other.

❑ Mix a generous amount of 30 minute epoxy and apply a thin layer to the exposed half of the wing joiner, the inside of the wing joiner box in the second wing panel, and the **entire surface of BOTH root ribs**. Make sure to use enough epoxy to fill any gaps.

❑ Slide the two wing panels together and realign them. Quickly wipe away any excess epoxy using a paper towel and rubbing alcohol, and use pieces of masking tape to hold the two wing panels aligned until the epoxy fully cures.

## Step 3: Checking the Center Section Joint

❑ Once the epoxy has fully cured, remove the masking tape and double-check the center section joint. If any gaps are present, mix a small amount of 30 minute epoxy and carefully fill any remaining gaps. Quickly remove any excess epoxy using a paper towel and rubbing alcohol, and allow the epoxy to thoroughly cure.

## SECTION 8: WING MOUNTING

### YOU'LL NEED THE FOLLOWING PARTS FROM THE KIT:

- (1) Fuselage
- (2) 5mm Flat Washers
- (2) 5mm x 40mm Machine Screws
- (2) 5mm Blind Nuts - Optional

### YOU'LL NEED THE FOLLOWING TOOLS AND SUPPLIES:

- Kwik Bond Thin C/A
- Ernst Airplane Stand
- # 2 Phillips Head Screwdriver
- Ruler
- Dubro 5mm Drill & Tap Set
- Pencil
- Electric Drill
- Masking Tape
- 5/32" & 13/64" Drill Bits

### Step 1: Aligning the Wing

- With the fuselage upside down, place the wing into the wing saddle and push the trailing edge down firmly into place.

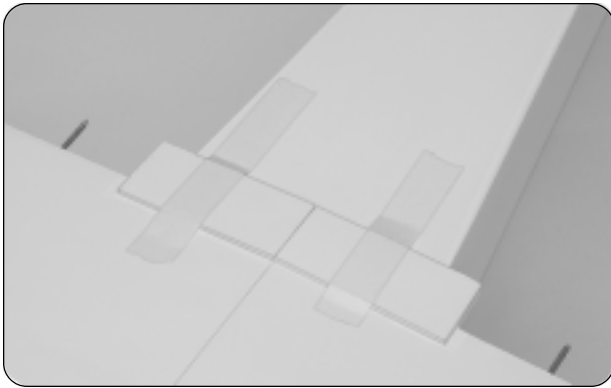

- Carefully align the centerline of the wing (the center joint) with the centerline of the fuselage, at the back of the wing saddle.
- Use a couple of pieces of masking tape to temporarily hold the wing aligned.

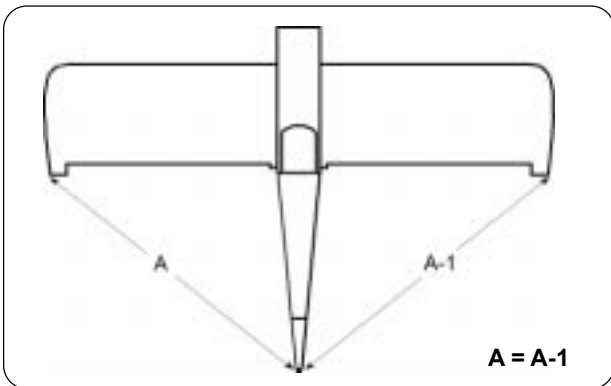

- With the wing held in place and aligned, use a ruler to measure from each wing tip to the back edge of each side of the fuselage. Move the trailing edge of the wing in the wing saddle until both measurements are equal.
- When satisfied with the alignment, again, hold the wing firmly in place using pieces of masking tape.

### Step 2: Tapping the Wing Hold-Down Block

#### IMPORTANT

Although the kit includes blind nuts to install in the wing hold-down block, we suggest tapping the block with a 5mm tap as we show. This is much easier than installing the blind nuts and is more accurate. Of course, you can opt to install the blind nuts if you want to. If you do opt to install the blind nuts, we strongly suggest carefully applying a bead of thick C/A around the base of the blind nuts, after installing them, so they don't pop loose while installing the wing.

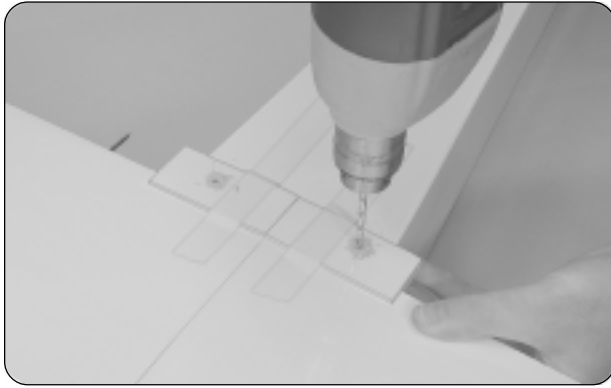

- ❑ Using an 5/32" diameter drill bit, drill two holes into the wing and through the plywood wing hold-down block inside the fuselage. Locate one hole in each wing panel, 1-3/4" out from the centerline and 5/8" in front of the trailing edge.

**IMPORTANT** Drill the two holes perpendicular to the bottom surface of the wing.



- ❑ Remove the wing from the fuselage and set it aside.
- ❑ Carefully apply several drops of thin C/A into both holes in the wing hold-down block and allow the C/A to dry completely before proceeding.

**WARNING** Let the C/A dry before proceeding to tap the holes. If you don't, the C/A will clog the tap badly and ruin the threads.



- ❑ After the C/A has fully cured, carefully tap the two holes using a 5mm tap. Work slowly, being careful not to damage the new threads you've just cut.
- ❑ After you're done tapping the threads, apply a couple of small drops of thin C/A into the holes and let it soak in. Allow the C/A to completely cure before proceeding.

**IMPORTANT** Do not omit this procedure. The C/A will strengthen the threads and help prevent them from being stripped out over time.

### Step 3: Mounting the Wing

- ❑ Using a 13/64" diameter drill bit, enlarge **only** the two wing mounting holes in the wing, so the wing hold-down bolts will slide through without binding.

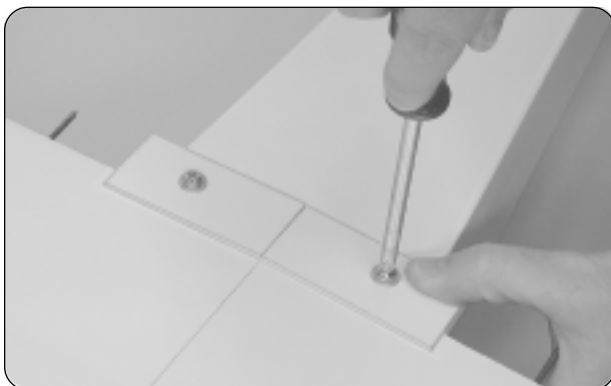

- ❑ Set the wing back into the wing saddle and realign it.
- ❑ Secure the wing into place using two 5mm x 40mm machine screws and two 5mm flat washers.
- 👉 Don't overtighten the screws. You don't want to crush the wing.

## SECTION 9: STABILIZER INSTALLATION

### YOU'LL NEED THE FOLLOWING PARTS FROM THE KIT:

- (1) Horizontal Stabilizer w/Elevator
- (1) Vertical Stabilizer w/Rudder

### YOU'LL NEED THE FOLLOWING TOOLS AND SUPPLIES:

- Kwik Bond 30 Minute Epoxy
- Excel Modeling Knife
- Dubro T-Pins
- Ernst Airplane Stand
- Ruler
- Pencil
- Builder's Triangle
- 220 Grit Sandpaper w/Sanding Block
- Masking Tape
- Paper Towels
- Rubbing Alcohol
- NHP Epoxy Mixing Sticks
- NHP Epoxy Mixing Cups

### Step 1: Aligning the Vertical Stabilizer

- Remove the rudder and hinges from the vertical stabilizer and set them aside for now.
- Remove the elevator and hinges from the horizontal stabilizer and set them aside.

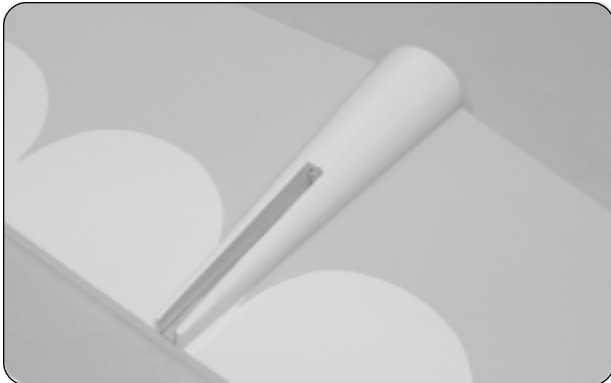

- Using a modeling knife, cut away and remove the covering material from over the vertical stabilizer mounting slot in the top of the horizontal stabilizer.



- Push the vertical stabilizer down into place. To align it properly, it should be even with the back edge of the horizontal stabilizer and it should be pushed down firmly.
- Using a builder's triangle, check to make sure that the vertical stabilizer is aligned 90° to the horizontal stabilizer.

### Step 2: Installing the Vertical Stabilizer

- While holding the vertical stabilizer firmly in place, use a pencil to draw a line on each side of the stabilizer where it meets the top of the horizontal stabilizer.

- ❑ Using a pencil, outline the front of the vertical stabilizer onto the top of the horizontal stabilizer.



- ❑ Remove the vertical stabilizer.
- ❑ Using a modeling knife, carefully cut away and remove the covering material from below the lines you drew. Cut away and remove the covering material from the base of the vertical stabilizer and inside the outline you drew on top of the horizontal stabilizer, too.

- ❑ Mix and apply a generous amount of 30 minute epoxy to the gluing surfaces of both the vertical stabilizer and the stabilizer mounting slot in the top of the horizontal stabilizer.
- ❑ Push the vertical stabilizer down into place and realign it, double-checking all of your measurements once more before the epoxy sets up. Quickly remove the excess epoxy and use pieces of masking tape to hold the stabilizer in place and aligned until the epoxy has fully cured.

### Step 3: Aligning the Horizontal Stabilizer Assembly



- ❑ Using a modeling knife, cut away and remove the covering material from the top of the stabilizer mounting sides.

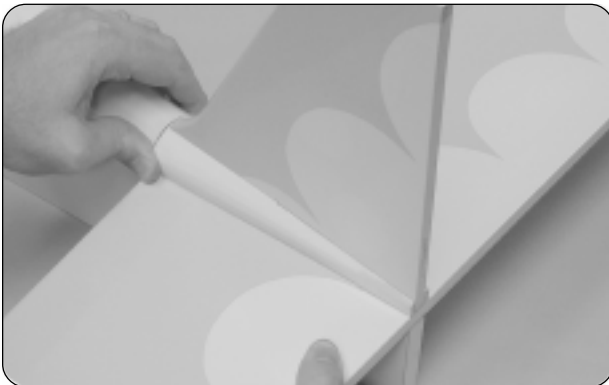

- ❑ Set the stabilizer assembly into place and temporarily align it. The fairing at the front of the stabilizer should be even with the top and sides of the fuselage and the fairing at the back of the stabilizer should be even with the sides of the fuselage. The trailing edge of the stabilizer should be even with the back edge of the fuselage, too.

- ❑ When satisfied with the alignment, hold the stabilizer in place using pieces of masking tape or several T-Pins.

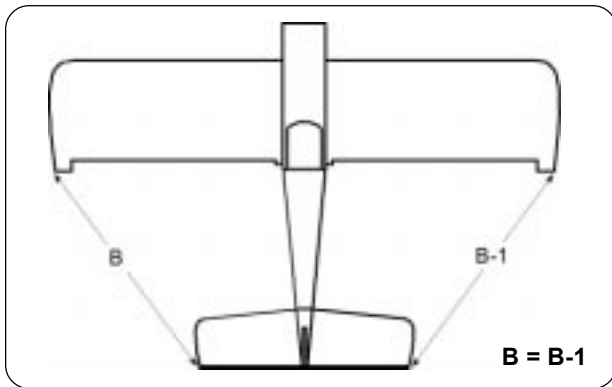

□ With the wing mounted to the fuselage, use a ruler to measure the distance between the tips of the stabilizer and the tips of the wing. Adjust the stabilizer until both of these measurements are equal.

☞ If the stabilizer is lined up correctly with the fuselage, the measurements should be very close. If you need to make adjustments, make sure to keep the back of the stabilizer lined up with the sides of the fuselage so that the rudder will line up with the fuselage when it's hinged later.

□ When you are satisfied that the stabilizer is square to the wing, use a pencil to draw a couple of marks on the **bottom** of each side of the stabilizer where it and the fuselage sides meet, then use pieces of masking tape or T-Pins to hold the stabilizer firmly in place and aligned.

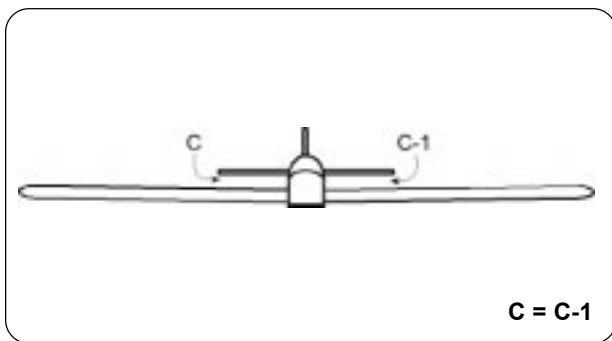

□ With the stabilizer held firmly in place, look from the front of the airplane at both the wing and the stabilizer. When aligned properly, the stabilizer should be parallel to the wing.

☞ If the stabilizer is out of alignment, remove it and use 220 grit sandpaper with a sanding block to sand down the higher side of the stabilizer mounting sides, then reinstall the stabilizer and check the alignment once more. Repeat this procedure until you are satisfied with the alignment.

#### Step 4: Installing the Horizontal Stabilizer Assembly

□ With the stabilizer assembly properly aligned, use a pencil to draw a line on the bottom of the stabilizer where it meets the fuselage sides.



□ Remove the stabilizer. Using a modeling knife, carefully cut away and remove the covering material from between the lines you drew. Remove the covering material from the front of the stabilizer fairing, too.

**WARNING** When cutting through the covering to remove it, cut with only enough pressure to cut through only the covering itself. Cutting down into the balsa structure could weaken the stabilizer and cause it to fail during flight.

□ Mix and apply a generous amount of 30 minute epoxy to the gluing surfaces of the stabilizer and to the top of the stabilizer mounting sides. Apply epoxy to the front of the stabilizer fairing, too.

□ Set the stabilizer assembly back into place and realign it, double-checking all of your measurements once more before the epoxy sets up. Quickly remove the excess epoxy and use pieces of masking tape or T-Pins to hold the stabilizer in place until the epoxy has fully cured.

## SECTION 10: CONTROL SURFACE HINGING

### YOU'LL NEED THE FOLLOWING PARTS FROM THE KIT:

- (17) C/A Style Hinges

### YOU'LL NEED THE FOLLOWING TOOLS AND SUPPLIES:

- Kwik Bond Thin C/A
- Kwik Bond 5 Minute Epoxy
- Kwik Bond C/A Debonder
- Excel Modeling Knife
- Ernst Airplane Stand
- Waxed Paper
- 220 Grit Sandpaper w/Sanding Block
- Paper Towels
- Rubbing Alcohol
- NHP Epoxy Mixing Sticks
- NHP Epoxy Mixing Cups

### Step 1: Hinging the Ailerons

For flutter-free control surfaces it is imperative that the hinges be glued in properly. This includes both having a tight hinge gap and using plenty of thin C/A glue.

☞ Each aileron is hinged using four hinges.

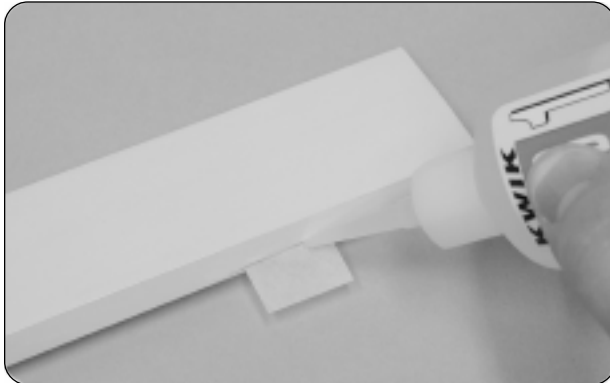

- Center each hinge within its precut slot in both ailerons. If you can't push the hinge in halfway, carefully cut the slot deeper using a modeling knife.

- Carefully glue each hinge into place using 5-6 drops of thin C/A on each side of the hinge. **Do not use thick C/A or epoxy. Use only thin C/A for proper adhesion.**

☞ If any C/A gets onto the aileron, it can be removed promptly using a paper towel soaked with a small quantity of C/A Debonder.

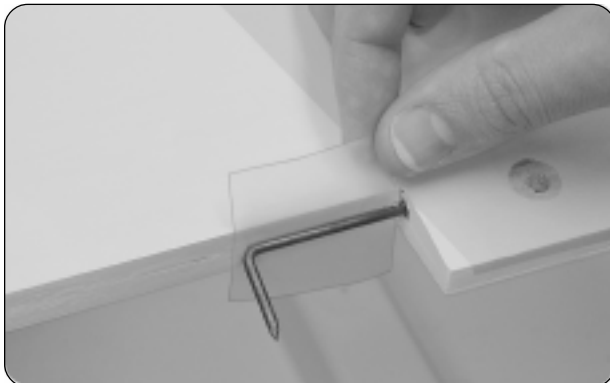

- Cut out a 1-1/2" square piece of waxed paper.

- Slide the waxed paper between the torque rod and the trailing edge of the wing on one wing half.

☞ The waxed paper will prevent epoxy from gluing the torque rod to the trailing edge.

- Mix a small quantity of 5 minute epoxy and apply a thin layer to the end of the aileron torque rod, and pack more into the predrilled hole and the precut groove in the leading edge of the aileron.

**IMPORTANT** Before applying the epoxy, make sure to cut away and remove any covering material from over the precut hole and groove in the aileron.

- ❑ Slide the aileron and its hinges into the hinge slots in the trailing edge of the wing, making sure that the torque rod is firmly seated in the leading edge of the aileron. Adjust the aileron so that the edges of the aileron don't rub against the edges of the wing.

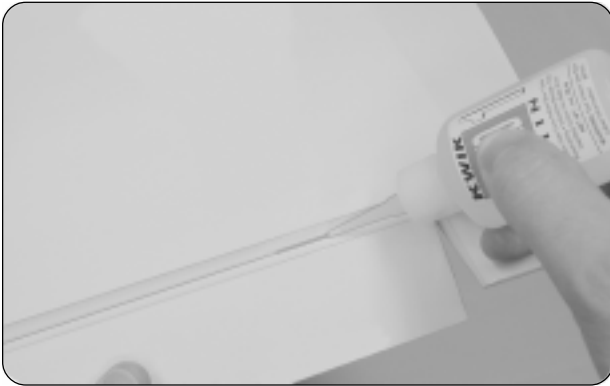

- ❑ While holding the aileron tight against the wing panel, pivot the aileron down about 45° and apply 5-6 drops of thin C/A to the exposed area of each hinge. Turn the wing panel over and repeat for the other side of the hinges.
- ☞ Remove any C/A that may run down the hinge line using C/A Debonder.
- ❑ Allow the C/A to dry for about 15 minutes, then pivot the aileron up and down to free up the hinges.

- ❑ Repeat the previous procedures to hinge the second aileron to the other wing panel.

**IMPORTANT** After the C/A and epoxy has fully cured, gently grasp each aileron and pull on it like you are trying to pull out the hinges. The hinges should hold securely. If one or more hinges feels loose, apply more C/A to the hinge(s) and allow it to completely cure.

## Step 2: Hinging the Elevator

☞ The elevator is hinged using six hinges.

- ❑ Hinge the elevator using the same methods as for the ailerons, making sure that the ends of the elevator are even with the ends of the stabilizer. Be sure to check the integrity of the hinges, after the C/A has fully cured, by pulling gently on the elevator.

**WARNING** Make sure you hinge the elevator **before** hinging the rudder. If you hinge the rudder first, you won't be able to hinge the elevator.

## Step 3: Hinging the Rudder

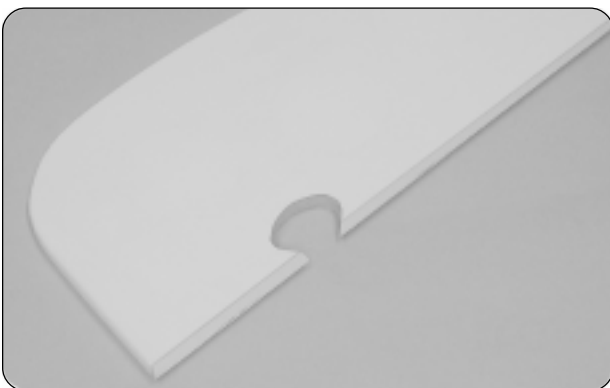

- ❑ Using a modeling knife, cut away and remove the covering material from over the precut notch in the leading edge of the rudder.

- ❑ Hinge the rudder using the three hinges provided, noting that the lower rudder hinge is installed in the back of the fuselage. Make sure that the top of the rudder is even with the top of the vertical stabilizer and that the rudder is pushed forward completely to minimize the hinge gap. Again, after the C/A cures, check the integrity of the hinges by pulling gently on the rudder.

## SECTION 11: TAIL WHEEL INSTALLATION

### YOU'LL NEED THE FOLLOWING PARTS FROM THE KIT:

- (1) Nylon Tail Wheel Bracket
- (1) Nylon Tail Wheel Tiller Arm
- (1) Prebent Tail Wheel Wire
- (1) Tail Wheel
- (2) Wheel Collars w/Set Screws
- (1) Nylon Spacer
- (1) 2.5mm x 12mm Wood Screw
- (3) 3mm x 12mm Wood Screws

### YOU'LL NEED THE FOLLOWING TOOLS AND SUPPLIES:

- # 1 Phillips Head Screwdriver
- Electric Drill
- 5/64" Drill Bit
- Ernst Airplane Stand
- Rotary Tool w/Cutting Disc
- Pencil
- Masking Tape

### Step 1: Assembling the Tail Wheel Bracket

- Push one wheel collar into the molded recess in the nylon tiller arm. Carefully rotate the wheel collar until the threaded hole in the collar lines up with the molded hole in the side of the tiller arm.

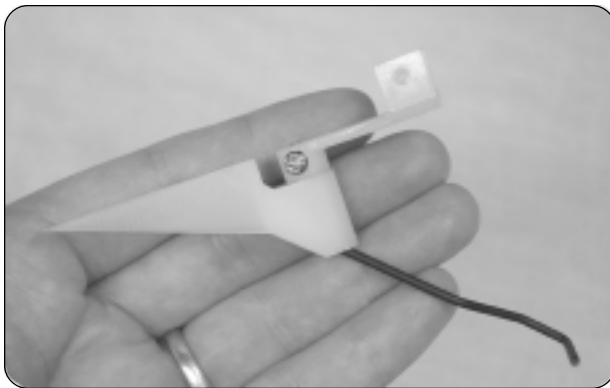

- Partially thread one set screw through the tiller arm and into the wheel collar.
- Push the tail wheel wire up through the tail wheel bracket, then slide the tiller arm over the wire and push it down against the bracket.
- Rotate both the tail wheel wire and the tiller arm so that they face the back of the bracket. While holding everything in alignment, tighten the machine screw.

- Using a rotary tool with a cutting disc, carefully cut the excess wire off flush with the nylon tiller arm.

👉 Be careful not to cut into the nylon tiller arm.

### Step 2: Mounting the Tail Wheel Bracket

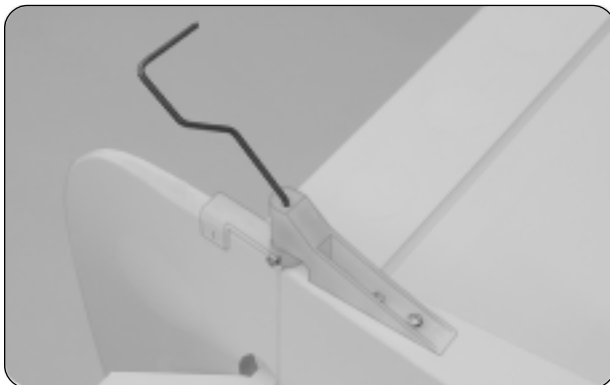

- Set the tail wheel bracket into place. To align the assembly, the pivot point of the tiller arm should be even with the rudder hinge line and the bracket should be centered on the bottom of the fuselage.

👉 The clasp of the tiller arm should fit over the bottom edge of the rudder, as shown.

- When satisfied with the alignment, drill three 5/64" diameter pilot holes through the fuselage for the wood screws.
- Mount the tail wheel assembly using three 3mm x 12mm wood screws.

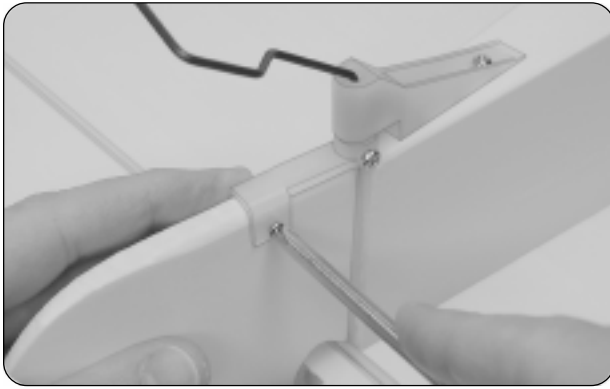

❑ While holding the tiller arm firmly against the bottom of the rudder, drill a 5/64" diameter pilot hole through both sides of the nylon clasp and through the rudder.

❑ Thread the 2.5mm x 12mm wood screw into one side of the clasp, through the rudder and into the other side of the clasp.

👉 Do not overtighten the screw or you might strip out the nylon clasp.

❑ Slide the nylon spacer onto the tail wheel wire, followed by the tail wheel. Use one wheel collar and set screw to hold the tail wheel in place.

❑ Loosen the machine screw in the side of the tiller arm. With the rudder centered, pivot the tail wheel wire until the tail wheel is aligned with the rudder. When satisfied with the alignment, tighten the machine screw firmly.

## SECTION 12: MAIN LANDING GEAR INSTALLATION

### YOU'LL NEED THE FOLLOWING PARTS FROM THE KIT:

- |                                        |                                      |
|----------------------------------------|--------------------------------------|
| ❑ (1) Prebent Aluminum Main Gear Strut | ❑ (4) 4mm Wheel Collars w/Set Screws |
| ❑ (2) Blow-Molded Wheel Pants          | ❑ (4) 4mm x 20mm Machine Screws      |
| ❑ (2) Main Gear Wheels                 | ❑ (4) 4mm Flat Washers               |
| ❑ (2) Plywood Mounting Plates (D36)    | ❑ (2) 3mm x 12mm Machine Screws      |
| ❑ (2) 4mm Threaded Axles w/Lock Nuts   | ❑ (2) 3mm Blind Nuts                 |

### YOU'LL NEED THE FOLLOWING TOOLS AND SUPPLIES:

- |                                 |                                      |
|---------------------------------|--------------------------------------|
| ❑ Kwik Bond Thick C/A           | ❑ Ernst Airplane Stand               |
| ❑ Kwik Bond 5 Minute Epoxy      | ❑ Ruler                              |
| ❑ # 1 Phillips Head Screwdriver | ❑ Pencil                             |
| ❑ # 2 Phillips Head Screwdriver | ❑ 220 Grit Sandpaper w/Sanding Block |
| ❑ Adjustable Wrench (2)         | ❑ Paper Towels                       |
| ❑ Modeling Knife                | ❑ Rubbing Alcohol                    |
| ❑ Electric Drill                | ❑ NHP Epoxy Mixing Sticks            |
| ❑ 5/32 & 3/8" Drill Bits        | ❑ NHP Epoxy Mixing Cups              |

### Step 1: Installing the Main Gear Strut



❑ Remove the covering material from over the four predrilled holes in the bottom of the fuselage, then install the landing gear strut using four 4mm x 20mm machine screws and four 4mm flat washers.

**IMPORTANT** The straight edge of the strut should be toward the **back** of the fuselage.

👉 Blind nuts have been preinstalled in the bottom of the landing gear mounting block for the machine screws.

## Step 2: Installing the Wheels & Wheel Pants



- ❑ Using a modeling knife, very carefully cut the wheel opening in each of the two wheel pants, as shown.
- ❑ Use 220 grit sandpaper with a sanding block to carefully sand the edges of the openings smooth.



- ❑ Using a 5/32" diameter drill bit, drill a hole through the molded dimple in **only one side** of one wheel pant.
- ❑ Using a modeling knife, carefully cut away the flashing on the inside of the wheel pant, that's left from drilling the hole.

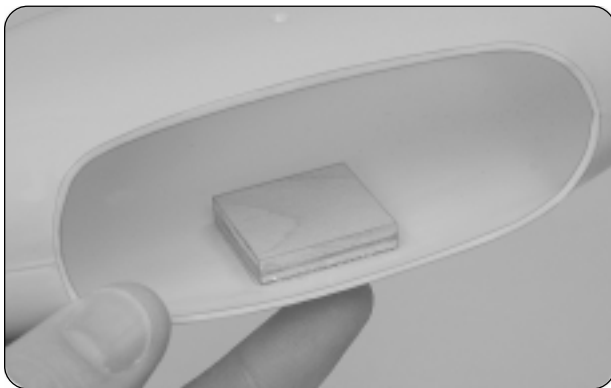

- ❑ Test-fit one of the plywood mounting plates to the inside of the wheel pant. The bottom edge of the plate should be about 3/8" above the bottom of the wheel pant and the plate should be centered from side-to-side over the 5/32" diameter hole you drilled.

- ❑ When satisfied with the fit, remove the plywood plate.
- ❑ Using 220 grit sandpaper, lightly sand the inside of the wheel pant where the plywood plate will be glued into place.

**IMPORTANT** Do not omit this procedure. Roughening the plastic will allow the epoxy to adhere to the plastic much better.

- ❑ Mix a generous amount of 5 minute epoxy and use a thin layer to glue the plywood plate into place. Remove any excess epoxy and hold the plate in place until the epoxy sets up.

**WARNING** Allow the epoxy to fully cure before proceeding or the plate might pop loose.

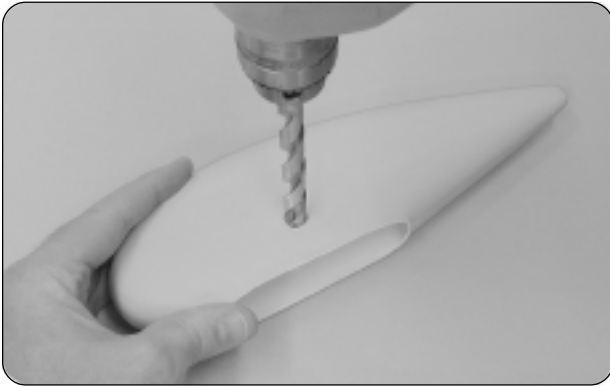

❑ After the epoxy has fully cured, carefully drill a 3/8" diameter hole through the wheel pant and plywood plate using the 5/32" diameter hole you drilled previously as a guide.

☞ The hole will not be centered within (and might even miss part of) the plywood plate. This is okay. The plate is there to strengthen the wheel pant and give a place to install the blind nut that secures the wheel pant to the strut.



❑ Using a modeling knife, carefully enlarge the 3/8" diameter hole until the head of the threaded axle will fit through the hole without binding.

☞ Don't enlarge the hole any more than necessary. You don't want the fit to be too loose.

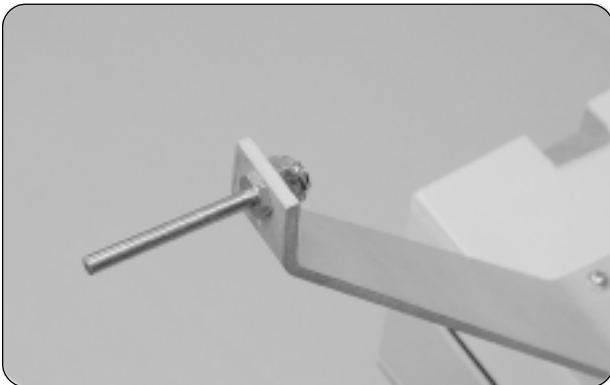

❑ Mount the threaded axle to the landing gear strut using the lock nut provided.

❑ While holding the axle in place with one adjustable wrench, use a second adjustable wrench to tighten the lock nut firmly.

❑ Temporarily install the wheel and the wheel pant to the axle in the following order: slide the wheel pant partially onto the axle, followed by one wheel collar. Slide the wheel onto the axle, then slide the second wheel collar up against the wheel.

❑ Adjust the wheel collars to center the wheel within the wheel pant, then tighten the set screws to hold them in place.



❑ While holding the wheel pant against the side of the strut, pivot the wheel pant so that the bottom, rear surface of the wheel pant is parallel with the bottom of the fuselage.

❑ When satisfied with the alignment, use a pencil to mark the location of the wheel pant mounting screw using the predrilled hole in the landing gear strut as a guide.

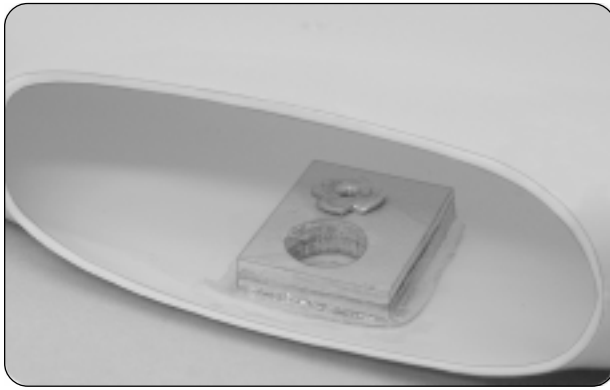

- ❑ Remove the wheel collars, wheel and wheel pant from the threaded axle.
- ❑ Using a 5/32" diameter drill bit, drill a hole into the wheel pant and through the plywood plate, at the mark you drew.
- ❑ Carefully install one 3mm blind nut, from inside the wheel pant, into the hole you just drilled.
- ❑ Apply a bead of thick C/A around the edge of the blind nut to keep it from coming loose.

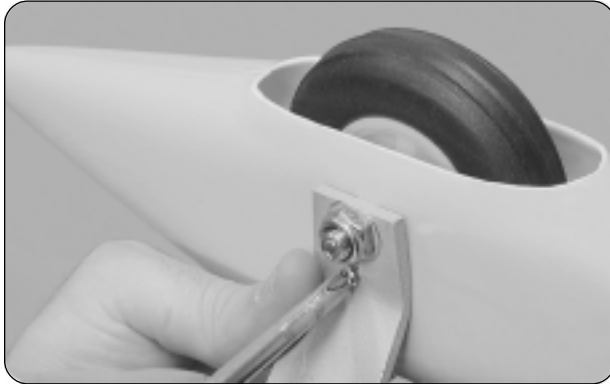

- ❑ Reinstall the wheel pant, wheel collars and wheel as done previously. Don't worry about centering the wheel yet.
- ❑ Pivot the wheel pant until the hole with the blind nut lines up with the hole in the strut.
- ❑ Thread one 3mm x 12mm machine screw through the hole in the strut and into the blind nut. Tighten the screw securely to hold the wheel pant firmly in place.

❑ With the wheel pant firmly in place, adjust the two wheel collars to center the wheel. When satisfied with the alignment, tighten the two set screws firmly, then repeat the previous procedures to install the second wheel and wheel pant assembly, making sure the second wheel pant is parallel with the first wheel pant.

## SECTION 13: ENGINE INSTALLATION

### YOU'LL NEED THE FOLLOWING PARTS FROM THE KIT:

- |                                                    |                                    |
|----------------------------------------------------|------------------------------------|
| ❑ (2) Engine Mounting Beams                        | ❑ (4) 4mm Blind Nuts               |
| ❑ (1) Plywood Engine Mount Spacer (F1A) - Optional | ❑ (4) 4mm x 25mm Socket-Cap Screws |
| ❑ (4) 4mm x 20mm Socket-Cap Screws                 | ❑ (4) 4mm Lock Nuts                |
| ❑ (4) 4mm x 30mm Socket-Cap Screws - Optional      | ❑ (12) 4mm Flat Washers            |

### YOU'LL NEED THE FOLLOWING TOOLS AND SUPPLIES:

- |                             |                           |
|-----------------------------|---------------------------|
| ❑ Kwik Bond 5 Minute Epoxy  | ❑ Ernst Airplane Stand    |
| ❑ Kwik Bond Thick C/A       | ❑ Ruler                   |
| ❑ Pacer Z-42 Threadlocker   | ❑ Pencil                  |
| ❑ 3mm Hex Wrench            | ❑ Paper Towels            |
| ❑ Adjustable Wrench         | ❑ Rubbing Alcohol         |
| ❑ Electric Drill            | ❑ NHP Epoxy Mixing Sticks |
| ❑ 7/64" & 11/64" Drill Bits | ❑ NHP Epoxy Mixing Cups   |

**IMPORTANT** The references in the next few procedures are taken from the consideration that you are looking at the front of the airplane with the airplane right-side up. The engine will be mounted on its side.

A precut plywood spacer has been provided if you are using an engine that is smaller than 1.08 - 1.20. This spacer allows smaller engines to be mounted farther forward to aid in balancing. An extra set of 30mm long socket-cap screws have also been included to use with the spacer.

## Step 1: Aligning the Engine Mounting Beams

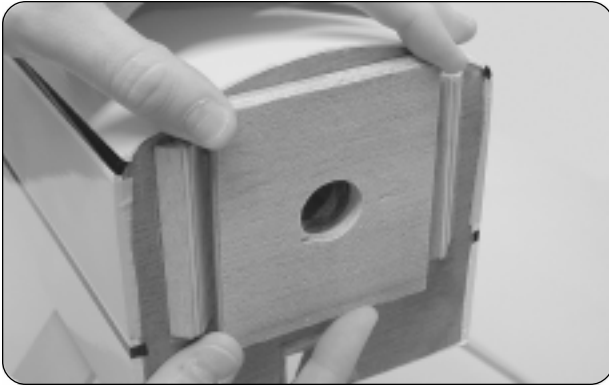

**IMPORTANT** If you'll be using an engine that is smaller than 1.08 - 1.20 size, begin by epoxying on the plywood spacer as described below. If you'll be using a 1.08 - 1.20 size engine, skip this procedure. The plywood spacer does not need to be installed.

☐ Carefully line up the plywood spacer onto the firewall and glue it into place using a generous amount of 5 minute epoxy. To line it up properly, the predrilled hole in the spacer should line up with the predrilled hole in the firewall and the sides of the spacer should be parallel to the firewall supports.

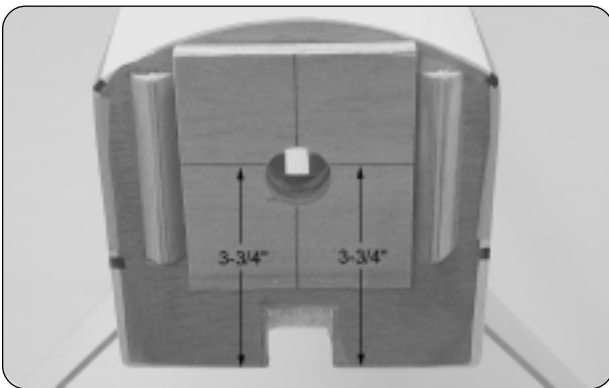

☐ Using a ruler and a pencil, draw a vertical centerline on the firewall.

☐ Using a ruler and a pencil, measure 3-3/4" **up** from the **bottom** of the firewall and draw a horizontal line. This will be referred to the "horizontal thrust line."



☐ Measure 1/4" to the **right** of the vertical centerline and draw a second vertical line parallel to it.

☞ This second vertical line will be referred to as the "vertical thrust line."

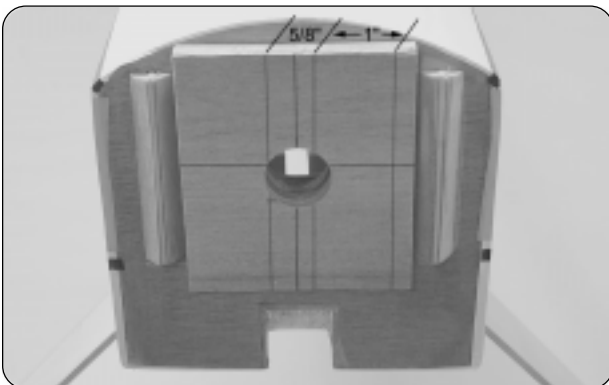

☐ Using a ruler and a pencil, measure and draw a vertical line 1" to the **right** of the **vertical thrust line**.

☐ Measure and draw a vertical line 5/8" to the **left** of the **vertical thrust line**.

☞ Do not measure from the centerline. Measure from the vertical thrust line.

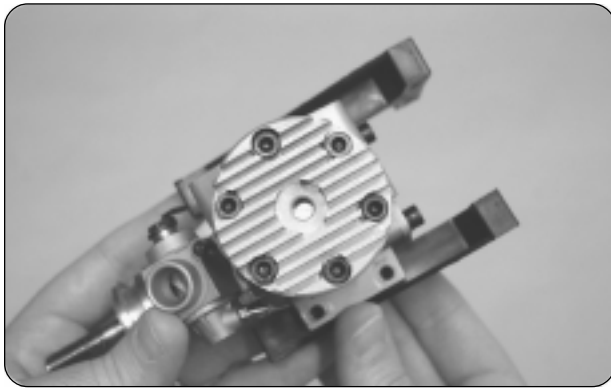

❑ Temporarily glue the two engine mounting beams to your engine's mounting lugs using a couple of drops of thick C/A.

☞ The location of the engine is not important at this time. It's more important that the beams are square to the mounting lugs.

❑ Using a ruler, measure the distance between the holes in the two engine mounting beams. As an example, for the Magnum XL .61ARNV engine used in this model, the distance between the holes in the two beams is 2-1/8". Your measurement may differ if you are using a different size engine. It depends on the width of the engine's crankcase.

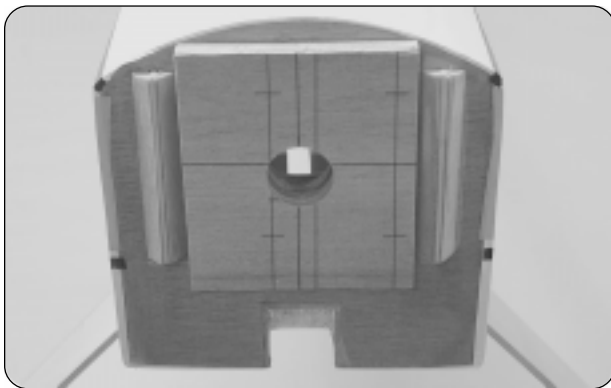

❑ Divide the measurement found in the previous procedure in half.

❑ Measure this resulting distance and draw one horizontal line above and one below the horizontal thrust line.

☞ As an example, if using the Magnum XL .61ARNV, you would draw the two lines 1-1/16" above and 1-1/16" below the horizontal thrust line.

## Step 2: Installing the Engine Mounting Beams

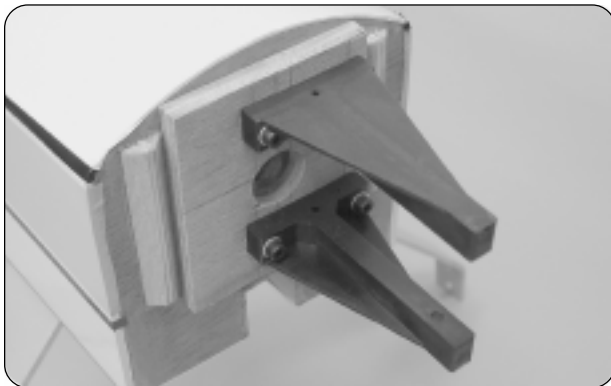

❑ Using a drill with an 11/64" diameter drill bit, drill a hole through the firewall at each of the four intersecting lines.

❑ Remove your engine from the mounting beams and install them using four 4mm x 30mm socket-cap screws, four 4mm flat washers and four 4mm blind nuts. Tighten the screws firmly to draw the blind nuts into the back of the firewall.

**IMPORTANT** If you're not using the plywood spacer, install the mounting beams using the shorter 4mm x 20mm screws.

## Step 3: Aligning and Installing the Engine

**IMPORTANT** Before installing your engine, please note below what the measurement from the firewall to the front of your engine's thrust washer should be:

**For 1.08 - 1.20 engines the measurement should be 5-3/8".**

**For .61 - .91 engines the measurement should be 5-7/8".**

**If you are using the plywood spacer, do not measure from the front of the spacer, measure from the front of the firewall.**

- ❑ Slide your spinner's backplate onto your engine and secure it in place using your engine's prop washer and nut.
- ❑ Set the engine onto the engine mounting beams.

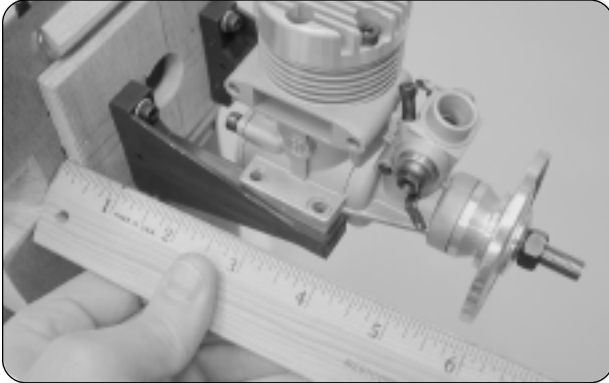

- ❑ Using a ruler, measure the distance from the firewall to the back of the spinner backplate (front of the thrust washer). Adjust the depth of the engine so the measurement is 5-7/8".

**IMPORTANT** If you're using a 1.08 or larger engine, the distance from the firewall to the front of the thrust washer should be 5-3/8".

- ☞ Measure from the firewall, even if you're using the plywood spacer. Do not measure from the front of the spacer.

- ❑ Using a pencil, mark the locations of the engine mounting holes onto the mounting beams. Remove the engine and drill the holes through the beams using an 11/64" diameter drill bit. Be careful to drill the holes straight down and not at an angle.

**IMPORTANT** Before mounting your engine in the next procedure, drill a 7/64" diameter hole through the firewall for the throttle pushrod wire. Drill the hole near the side of the fuselage so it does not interfere with the fuel tank when it's installed later. We located the hole 2" up from the bottom of the fuselage and 1-1/8" in from the side of the fuselage.

- ❑ Install the engine using four 4mm x 30mm socket-cap screws, eight 4mm flat washers and four 4mm lock nuts.

## SECTION 14: FUEL TANK ASSEMBLY & INSTALLATION

### YOU'LL NEED THE FOLLOWING PARTS FROM THE KIT:

- |                                  |                                |
|----------------------------------|--------------------------------|
| ❑ (1) 360cc Fuel Tank            | ❑ (1) Fuel Pick-Up "Clunk"     |
| ❑ (1) Large Diameter Metal Plate | ❑ (1) 3mm x 20mm Machine Screw |
| ❑ (1) Small Diameter Metal Plate | ❑ (1) Silicon Fuel Tubing      |
| ❑ (1) Rubber Stopper             | ❑ (2) Aluminum Tubing          |

### YOU'LL NEED THE FOLLOWING TOOLS AND SUPPLIES:

- |                                 |                                      |
|---------------------------------|--------------------------------------|
| ❑ # 1 Phillips Head Screwdriver | ❑ Ernst Airplane Stand               |
| ❑ Excel Modeling Knife          | ❑ Ruler                              |
| ❑ Scissors                      | ❑ 220 Grit Sandpaper w/Sanding Block |

### Step 1: Assembling the Rubber Stopper

- ❑ Using 220 grit sandpaper, carefully smooth and deburr each end of the two aluminum tubes. This will prevent the fuel tubing from being accidentally cut when it is installed later.
- ❑ Push the two aluminum tubes through the rubber stopper. Slide the large diameter metal plate over the tubes at the front of the stopper and slide the small diameter metal plate over the tubes at the rear of the stopper.

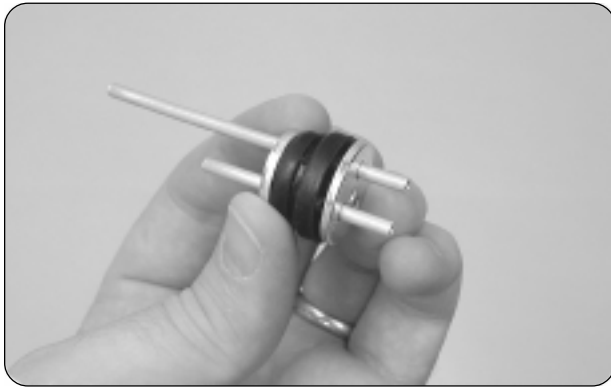

- ❑ Using a ruler, measure the distance that the two aluminum tubes protrude from the front of the stopper assembly. This distance should be 3/8". If it is not, adjust the tubes by pushing them forward or backward until you are satisfied with the alignment.

- ❑ Carefully bend the longer of the two aluminum tubes up at a 45° angle, being careful not to "kink" the tubing as you bend it.

☞ When the stopper assembly is installed in the fuel tank, the top of the vent tube (the tube you just bent) should rest just inside the bubble in the top of the tank.

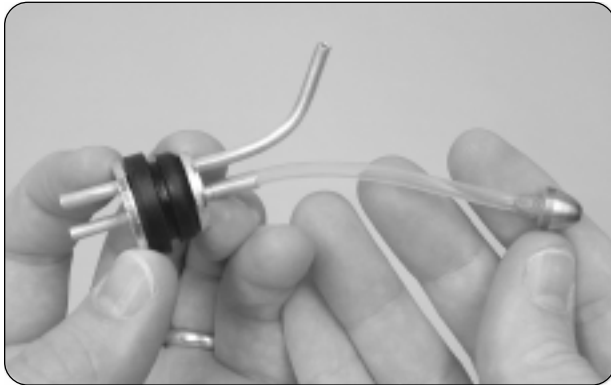

- ❑ Secure one end of the silicon fuel tubing onto the end of the fuel pick-up "clunk."

- ❑ Slide the silicon fuel tubing, with the fuel pick-up attached, onto the end of the aluminum fuel pick-up tube (straight tube). While holding the aluminum tube in place, adjust the length of the silicon tubing until the fuel pick-up is 4-3/8" back from the rear of the stopper assembly.

- ❑ Push the 3mm x 20mm machine screw through the stopper assembly, from the front, and partially thread it into the small diameter metal backplate.

## Step 2: Installing the Stopper Assembly

- ❑ Carefully push the stopper assembly into the molded hole in the front of the fuel tank. Gently rotate the stopper assembly until the aluminum vent tube rests just inside the bubble in the top of the tank.

☞ If you have trouble seeing the vent tube, hold the fuel tank assembly up to a bright light. This will illuminate the inside of the tank, making it easy to see the tubing inside.

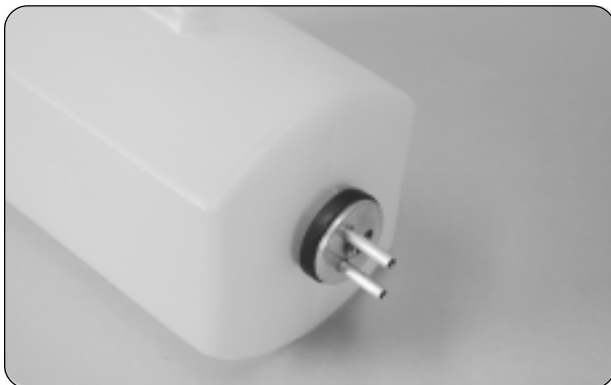

- ❑ When satisfied with the alignment, tighten the machine screw until the rubber stopper expands and seals the fuel tank opening.

**WARNING** Do not overtighten the screw. This could cause the front of the fuel tank to split.

- ❑ With the stopper assembly in place, double-check to make sure the fuel pick-up can move freely inside the tank. Ideally, the fuel pick-up should be about 1/4" in front of the back of the tank.

### Step 3: Installing the Fuel Tank Assembly

- ❑ Cut two pieces of silicon fuel tubing to a length of 8" and install them onto the aluminum tubes at the front of the tank.

☞ For your convenience, we suggest marking the free ends of the tubing "vent" and "pick-up" so you don't confuse them when it comes time to connect them to the engine later on.

- ❑ Feed the ends of the fuel tubing through the predrilled hole in the firewall and slide the fuel tank into position, making sure that the stopper assembly lines up with, and is pushed into, the predrilled hole in the firewall. When aligned properly, the tank should be pushed forward as far as possible and the back of the tank should rest on the plywood tank support.

**IMPORTANT** Make sure that the top of the fuel tank is toward the top of the fuselage.



- ❑ Cut and install several pieces of foam rubber between the top of the fuel tank and the top of the fuselage to wedge the back of the fuel tank securely into place.

☞ Make sure the foam will not interfere with installation of the throttle pushrod wire.

☞ An alternative to securing the fuel tank into place is to use silicon adhesive to glue the back of the fuel tank to the plywood tank support. If you do this, it would be a good idea to roughen the gluing surface of the tank so the silicon will stick better to the plastic.

## SECTION 15: SERVO INSTALLATION

### YOU'LL NEED THE FOLLOWING PARTS FROM THE KIT:

- ❑ (1) Plywood Aileron Servo Tray
- ❑ (1) Plywood Fuselage Servo Tray

### YOU'LL NEED THE FOLLOWING TOOLS AND SUPPLIES:

- ❑ Kwik Bond 5 Minute Epoxy
- ❑ # 1 Phillips Head Screwdriver
- ❑ Excel Modeling Knife
- ❑ Electric Drill
- ❑ 1/16" Drill Bit
- ❑ Ernst Airplane Stand
- ❑ Pencil
- ❑ Paper Towels
- ❑ Rubbing Alcohol
- ❑ NHP Epoxy Mixing Sticks
- ❑ NHP Epoxy Mixing Cups

### Step 1: Installing the Elevator, Rudder & Throttle Servos

- ❑ Install the rubber grommets and brass collets onto your elevator, rudder and throttle servos, making sure to install the collets with the flanges toward the bottom of the servo.

### BEFORE INSTALLING THE SERVOS, PLEASE READ THIS!

The Dragon Lady 60 is designed to use four servos. For the elevator and rudder servos, we have designed several different options for their mounting location. Typically, these servos would be mounted inside the fuselage on a plywood tray, which we have provided. This tray can be moved forward or aft several inches which will affect the overall balance of the airplane. If you're using a small, lightweight engine, you should install the servos inside the fuselage with the servo tray as far forward as possible. If you're using a mid-size, moderately heavy engine, we suggest installing the servos inside the fuselage with the servo tray pushed back as far as possible. If you're using a large, heavy engine, we strongly suggest installing the servos into the precut holes in the sides of the fuselage, near the tail.

If you decide to install your elevator and rudder servos in the sides of the fuselage, near the tail, please see Section 27 on page # 40 for information on installing the servos and control linkages in this configuration.



- ❑ Test-fit and glue the servo tray into the fuselage using a generous amount of 5 minute epoxy.

👉 Because we are using a light, .61 size engine, we have installed the servo tray as far forward as possible.

**IMPORTANT** After gluing the tray in place, you may need to trim the edges of the servo tray supports so they don't interfere with the servos.

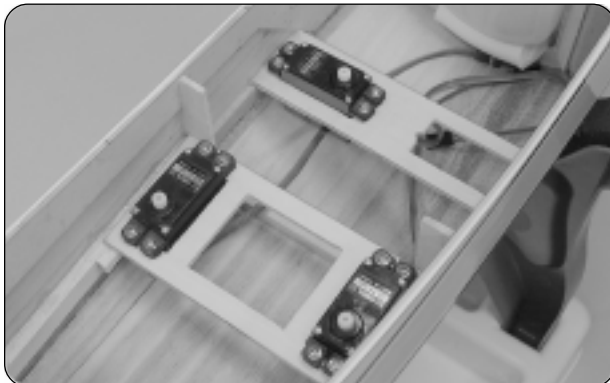

- ❑ Install the throttle, elevator and rudder servos into the servo trays, making sure the servo output shafts are orientated as shown.

**IMPORTANT** Install the throttle servo on the same side that your engine's throttle arm is located.

👉 To make it easier to install the servo mounting screws, first drill 1/16" pilot holes through the servo tray.

### Step 2: Installing the Aileron Servo

- ❑ Install the rubber grommets and brass collets onto your aileron servo, making sure to install the collets with the flanges toward the bottom of the servo.



- ❑ Center the aileron servo tray over the servo cutout in the top of the wing.

❑ While holding the servo tray in place, trace around it using a pencil.

- ❑ Remove the servo tray. Using a modeling knife, cut away and remove the covering material from within the outline you drew.
- ❑ Glue the servo tray into place using a generous amount of 5 minute epoxy. Remove any excess epoxy using a paper towel and rubbing alcohol, and allow the epoxy to set up before proceeding.

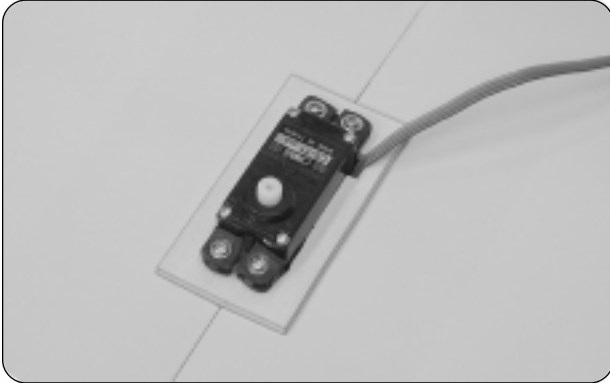

- ❑ Install the aileron servo into the servo tray, making sure the servo output shaft is toward the **trailing edge** of the wing.

☞ To make it easier to install the servo mounting screws, first drill 1/16" pilot holes through the servo tray.

**IMPORTANT** Use a modeling knife to cut a small notch in the side of the servo tray for the aileron servo lead to exit.

## SECTION 16: THROTTLE LINKAGE INSTALLATION

### YOU'LL NEED THE FOLLOWING PARTS FROM THE KIT:

- ❑ (1) 17-3/4" Pushrod Wire w/Z-Bend
- ❑ (1) Adjustable Servo Connector Assembly

### YOU'LL NEED THE FOLLOWING TOOLS AND SUPPLIES:

- ❑ Kwik Bond Thin C/A
- ❑ # 1 Phillips Head Screwdriver
- ❑ Wire Cutters
- ❑ Needle Nose Pliers
- ❑ Excel Modeling Knife
- ❑ Electric Drill
- ❑ 5/64" Drill Bit
- ❑ Ernst Airplane Stand

### Step 1: Installing the Throttle Pushrod Wire

- ❑ Remove the throttle arm from your engine and install the Z-Bend in the pushrod wire into the outermost hole in the throttle arm.



- ❑ Slide the pushrod through the hole you drilled previously in the firewall and reinstall the throttle arm onto your engine.

### Step 2: Installing the Adjustable Servo Connector

- ❑ Using a modeling knife, carefully cut away all but one arm from a large "4-point" servo horn.



- ❑ Enlarge the **fourth hole** out from the center of the servo arm using a 5/64" drill bit.

- ❑ Install the adjustable servo connector into the servo arm.

**IMPORTANT** When threading on the connector nut, don't tighten the nut completely. You don't want the connector loose, but you do want it to be able to rotate without binding.

- ❑ To prevent the connector nut from loosening during flight, apply a drop of thin C/A to it. Allow the C/A to dry before proceeding.

- ❑ Connect your radio system and plug the throttle servo (forward-most servo) into the receiver. Check to ensure that the throttle servo output shaft is rotating in the correct direction. When the throttle control stick is moved forward, from the idle to the full throttle position, the servo output shaft should rotate clockwise. If it doesn't, flip the servo reversing switch on your transmitter.

- ❑ Position the throttle control stick and the throttle trim lever on your transmitter at their lowest positions. Slide the adjustable servo connector/servo horn assembly over the plain end of the throttle pushrod wire.



- ❑ After making sure that the carburetor is in the fully **closed** position, angle the servo horn back about 45° from center and attach it to the servo output shaft. The servo connector should be facing the side of the fuselage.

- ❑ While holding the carburetor barrel fully closed, install and tighten the set screw in the top of the adjustable servo connector.

- ❑ Use wire cutters to cut away and remove the excess pushrod wire.

☞ You may have to make a slight bend in the pushrod wire so that it lines up evenly with the servo connector.

- ❑ Install and tighten the servo horn retaining screw to hold the servo horn securely to the servo.

## SECTION 17: ELEVATOR & RUDDER CONTROL SYSTEM INSTALLATION

### YOU'LL NEED THE FOLLOWING PARTS FROM THE KIT:

- (2) 31" Threaded Wires
- (2) Nylon Control Horns w/Backplates
- (4) 2mm x 20mm Machine Screws
- (2) Nylon Clevises
- (2) Nylon 90° Snap Keepers

### YOU'LL NEED THE FOLLOWING TOOLS AND SUPPLIES:

- # 1 Phillips Head Screwdriver
- Wire Cutters
- Needle Nose Pliers
- Excel Modeling Knife
- Electric Drill
- 5/64" Drill Bit
- Ernst Airplane Stand
- Ruler
- Pencil
- Masking Tape

### Step 1: Installing the Elevator Pushrod Assembly

- Using a modeling knife, cut away and remove the covering material from over the elevator pushrod exit hole in the **right side** of the fuselage. The hole is located 4-1/4" in front of the rudder hinge line and 7/8" below the horizontal stabilizer.
- Slide one 31" long pushrod wire (plain end first) into the preinstalled pushrod housing in the fuselage side.
- Use a couple of pieces of masking tape to hold the elevator centered.



- Position one nylon control horn onto the bottom of the elevator, aligning the control horn with the pushrod wire. The centerline of the control horn should be about 5/8" out from the side of the fuselage.
- Angle the control horn about 1/16" toward the fuselage side so it will line up better with the pushrod wire and adjust the control horn so that the clevis attachment holes are directly over the hinge line.

- Mark the positions of the control horn mounting screws, then remove the control horn and set it aside.
- Drill the holes through the elevator for the mounting screws using a 5/64" diameter drill bit.
- Install the control horn and backplate using two 2mm x 20mm machine screws, being careful not to overtighten them.

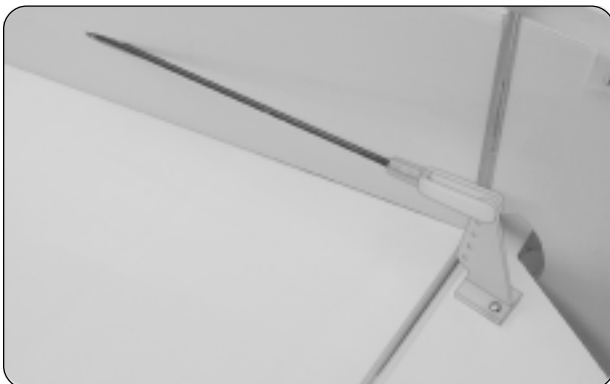

- Thread one clevis onto the pushrod wire and snap it into the outermost hole in the control horn.
-  Hold the pushrod wire with a pair of pliers to prevent it from turning while installing the clevis.

- ❑ Using a modeling knife, carefully cut away all but one arm from a large "4-point" servo horn.
- ❑ Enlarge the **third hole** out from the center of the servo arm using a 5/64" diameter drill bit.

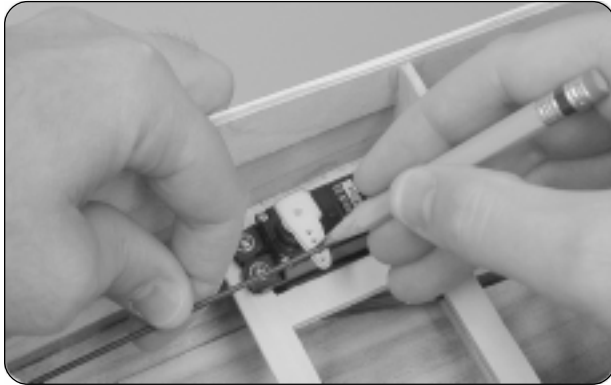

- ❑ Connect your radio system, plug the elevator servo into the receiver (the servo on the right side of the fuselage), then center the servo.
- ❑ Attach the servo horn to the servo, making sure it's centered and points toward the middle of the fuselage.
- ❑ With the elevator and the servo horn centered, draw a mark on the elevator pushrod wire where it crosses the **third hole** out from the center of the servo horn.

- ❑ Unsnap the clevis from the control horn and remove the pushrod from the fuselage.
- ❑ Using a pair of pliers, carefully bend the pushrod wire down at a 90° angle (at the mark you drew) and cut off the excess, leaving 5/16" of wire beyond the bend.



- ❑ Remove the clevis from the pushrod wire and slide the threaded end of the wire into the pushrod housing from **inside** the fuselage.
- ❑ Secure the pushrod wire to the servo horn using one nylon 90° snap keeper.
- ❑ Install and tighten the servo horn retaining screw to secure the servo horn to the servo.

- ❑ Again, making sure that the elevator and the control horn are still centered, thread the clevis onto the pushrod wire and snap it into the **outermost hole** in the control horn.

## Step 2: Installing the Rudder Pushrod Assembly

- ❑ Using a modeling knife, cut away and remove the covering material from over the rudder pushrod exit hole in the **left side** of the fuselage. The hole is located 2-7/8" in front of the rudder hinge line and 1" below the horizontal stabilizer.



- ❑ The rudder pushrod assembly is installed using the same procedures as the elevator pushrod assembly. Snap the clevis into the **third hole** out from the base of the control horn.
- ☞ The rudder control horn should be installed 1-3/4" up from the bottom of the rudder. Adjust the control horn so that the base of the control horn is parallel to the hinge line and the clevis attachment holes are over the hinge line.

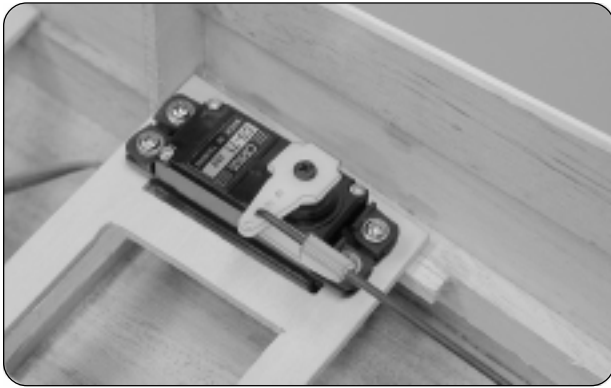

- ❑ Install the rudder pushrod into the **third hole** out from the center of the servo horn. Also, don't forget to install and tighten the servo horn retaining screw.

## SECTION 18: AILERON CONTROL SYSTEM INSTALLATION

### YOU'LL NEED THE FOLLOWING PARTS FROM THE KIT:

- |                                        |                              |
|----------------------------------------|------------------------------|
| ❑ (2) 4-1/2" Threaded Wires w/90° Bend | ❑ (2) Nylon Clevises         |
| ❑ (2) Nylon Adjustable Control Horns   | ❑ (2) Nylon 90° Snap Keepers |

### YOU'LL NEED THE FOLLOWING TOOLS AND SUPPLIES:

- |                                 |                   |
|---------------------------------|-------------------|
| ❑ # 1 Phillips Head Screwdriver | ❑ Electric Drill  |
| ❑ Needle Nose Pliers            | ❑ 5/64" Drill Bit |
| ❑ Excel Modeling Knife          | ❑ Masking Tape    |

### Step 1: Installing the Aileron Pushrod Assembly

- ❑ Using a modeling knife, cut away two arms from a large "4-point" servo horn.

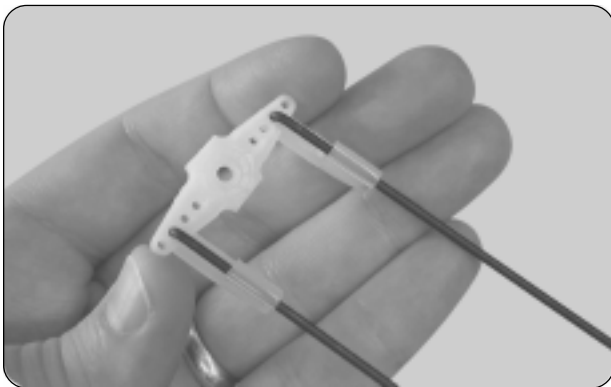

- ❑ Enlarge the **third hole** out from the center of each servo arm using a 5/64" diameter drill bit.

- ❑ Install the 90° bend in each aileron pushrod wire into the holes that you just enlarged, using the snap keepers provided.

☞ The pushrod wires should be on top of the servo arms as shown.

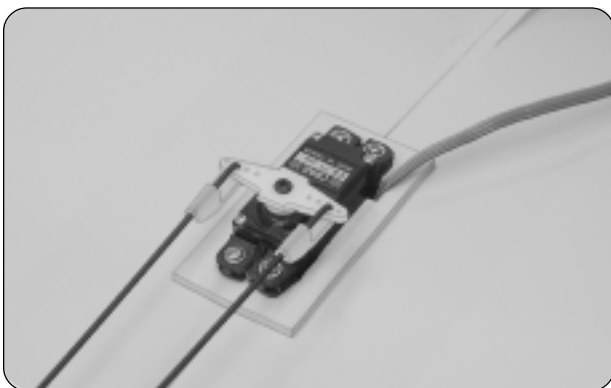

- ❑ Center the aileron servo and install the servo arm assembly making sure that the servo arm is centered.

- ❑ Install and tighten the servo arm retaining screw.

- ❑ Use a couple of pieces of masking tape to hold each of the ailerons centered.

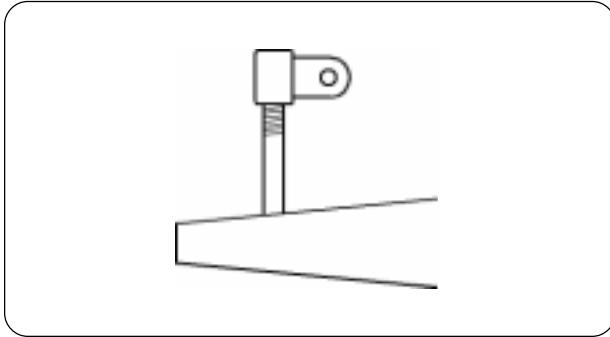

- ❑ Thread one adjustable control horn onto each aileron torque rod.

☞ Both control horns should be even with the tops of the torque rods, as shown in the drawing.



- ❑ Thread one nylon clevis onto each pushrod wire.
- ❑ Making sure both ailerons and the servo arm are centered, snap the clevises into the adjustable control horns.

## SECTION 19: COWLING INSTALLATION

### YOU'LL NEED THE FOLLOWING PARTS FROM THE KIT:

- |                                     |                        |
|-------------------------------------|------------------------|
| ❑ (1) Prepainted Fiberglass Cowling | ❑ (4) 3mm Flat Washers |
| ❑ (4) 3mm x 10mm Wood Screws        |                        |

### YOU'LL NEED THE FOLLOWING TOOLS AND SUPPLIES:

- |                                             |                                      |
|---------------------------------------------|--------------------------------------|
| ❑ Kwik Bond Thin C/A                        | ❑ Ruler                              |
| ❑ Electric Drill                            | ❑ Pencil                             |
| ❑ 5/64" & 1/8" Drill Bits                   | ❑ 220 Grit Sandpaper w/Sanding Block |
| ❑ Ernst Airplane Stand                      | ❑ Masking Tape                       |
| ❑ Rotary Tool w/Cutting Disc & Sanding Drum |                                      |

### Step 1: Aligning the Cowling

- ❑ Remove the needle valve and muffler assembly from your engine.
- ❑ Temporarily slide the cowling over the engine and onto the fuselage.

☞ Depending on the engine you've chosen, and how it's mounted, you may need to cut away a portion of the cowling to clear the engine's cylinder head. If so, use a rotary tool with a cutting disc and a sanding drum to make the cutout. Work slowly, checking the fit often so you don't remove too much of the cowling or damage it. For our Magnum XL .61ARNV engine, the cylinder head fit inside the cowling, so we needed to only cut a hole for access to the glow plug.

- ❑ With the cowling temporarily in place, secure the spinner backplate to the engine's crankshaft.



- ❑ Line up the front of the cowling using the backplate as your guide. When aligned properly, the cowl ring should be centered with the spinner backplate and there should be about a 1/16" - 1/8" gap between the two. The stripes on the sides of the cowling should also be lined up with the stripes on the sides of the fuselage.

- ❑ When satisfied with the alignment, use pieces of masking tape to hold the cowling securely in place and aligned.

## Step 2: Installing the Cowling

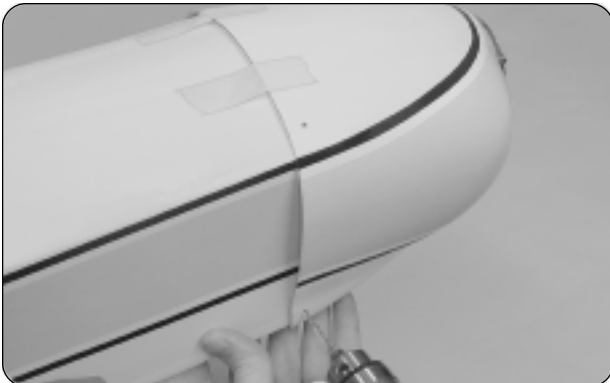

- ❑ With the cowling held firmly in place, drill 5/64" diameter pilot holes into the cowling and through the fuselage for the four wood screws. Locate one hole on each side of the cowling, about 1/2" up from the bottom, and locate the remaining two holes on top of the cowling, equally spaced apart.

👉 So the screws don't miss the fuselage, make sure not to drill the pilot holes any farther forward from the back edge of the cowling than 3/16".

- ❑ Remove the cowling and enlarge **only** the holes in the cowling using a 1/8" drill bit. Enlarging the holes will prevent the fiberglass from being cracked when you install the wood screws.
- ❑ To strengthen the holes in the fuselage that the wood screws will thread into, carefully apply a couple of drops of thin C/A into the holes and let it dry completely before installing the cowling.
- ❑ At this time you should make the rest of the cut-outs in the cowling for your engine. These include cut-outs for the high and low speed needle valves, glow igniter, muffler assembly and fueling valve assembly.

**IMPORTANT** We strongly suggest cutting an air-exit hole in the bottom of the cowling along with the opening needed to clear your muffler. For proper engine cooling, it's important to have about 30 percent more air-exit area than air-intake area.

- ❑ After making the rest of the necessary cut-outs, install your fueling valve, then slide the cowling partially into place and connect the fuel lines from the fuel tank to the fueling valve, carburetor and muffler pressure tap.
- ❑ Slide the cowling into position and realign it. Install and tighten the four 3mm x 10mm wood screws and four 3mm flat washers to hold the cowling firmly in place.
- ❑ Install your propeller and spinner cone to finish off the installation.

## SECTION 20: FINAL ASSEMBLY

### YOU'LL NEED THE FOLLOWING PARTS FROM THE KIT:

- (1) Clear Plastic Windscreen
- (2) 2mm x 6mm Wood Screws
- (1) Decal Sheet

### YOU'LL NEED THE FOLLOWING TOOLS AND SUPPLIES:

- Kwik Bond Thin C/A
- # 1 Phillips Head Screwdriver
- Scissors
- Electric Drill
- 1/16" & 5/64" Drill Bits
- Ernst Airplane Stand
- Ruler
- 220 Grit Sandpaper w/Sanding Block
- Masking Tape

### Step 1: Installing the Windscreen

- Using a pair of scissors, carefully cut out the windscreen along the molded scribe line.
- Using 220 grit sandpaper with a sanding block, carefully sand the edges of the windscreen smooth.



- Test-fit the windscreen to the fuselage, as shown. The base of the windscreen should be about 3/8" in front of the cockpit opening and the windscreen should be centered over the fuselage.
- When satisfied with the alignment, hold the corners of the windscreen in place using pieces of masking tape.

- Drill a 1/16" diameter pilot hole into each corner of the windscreen and through the fuselage for the screws.
- Remove the windscreen and apply a couple of drops of thin C/A into the holes in the fuselage to strengthen them.
- After the C/A fully cures, secure the windscreen to the fuselage using two 2mm x 6mm wood screws.

### Step 2: Installing the Receiver, Battery Pack & Switch

We don't suggest permanently installing the receiver and battery until you have balanced the airplane. Depending on how the airplane initially balances will determine where you need to mount the receiver and battery.

- Wrap the receiver and battery in foam rubber to protect them from vibration. Use masking tape or rubber bands to hold the foam in place.

👉 Do not wrap the foam rubber too tightly or its vibration dampening quality will be reduced.

- After you've found the final location of the receiver and battery, mount them into the fuselage using your favorite method. Strips of Velcro® work good or sandwich them in place using a couple of scraps of balsa wood glued between the fuselage sides.

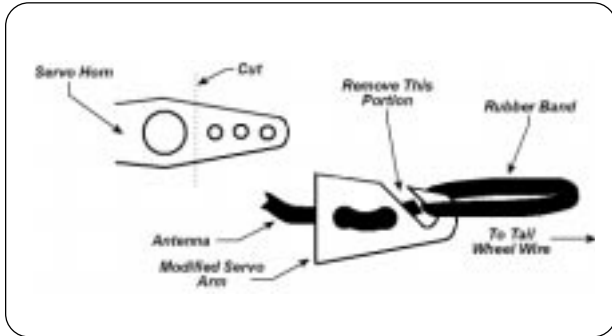

- After you have the receiver installed, drill a 5/64" diameter hole in the fuselage for the antenna to exit. Unwrap the receiver antenna and feed it out through the hole.
- Using a modeling knife, carefully make an antenna mount out of an extra servo horn. Remove one of the arms and cut it into the shape shown.
- Use the modified servo arm and a rubber band to secure the end of the antenna to the tail wheel wire.

- Mount the switch into the precut hole in the side of the fuselage and connect the battery lead to the switch, and the switch and servo leads to the receiver.

### Step 3: Applying the Decals

- Cut out and apply the decals using the box cover photos as your guide. If any air bubbles form under the decals you can "prick" the bubbles with a straight pin to release the air.

## SECTION 21: BALANCING THE DRAGON LADY 60 ARF

### YOU'LL NEED THE FOLLOWING TOOLS AND SUPPLIES:

- # 2 Phillips Head Screwdriver
- Masking Tape
- Ruler

**IMPORTANT** It is critical that your airplane be balanced correctly. Improper balance will cause your airplane to lose control and crash!

### Center of Gravity Location:

**3-3/8" to 4-1/8" back from the leading edge of the wing, at the fuselage sides.**

**WARNING** This is the recommended C.G. range. For test-flying we suggest you start with the C.G. in the middle of the range, then move it farther back as you become familiar with the flying characteristics of the airplane. It is not recommended that the C.G. be located any farther back than 4-1/8".

☞ Always balance the airplane with the fuel tank **empty**.

- Install the wing onto the fuselage. Apply two short pieces of masking tape onto the **top** of the wing, 3-3/4" back from the leading edge, at the fuselage sides.

- Turn the airplane upside down and place your fingers on the masking tape, and carefully lift the airplane. If the nose of the airplane falls, the airplane is nose heavy. To correct this, move the battery pack and/or receiver back far enough to bring the airplane into balance. If the tail of the airplane falls, the airplane is tail heavy. To correct this, move the battery pack and/or receiver far enough forward to bring the airplane into balance. When balanced correctly, the airplane should sit level or slightly nose down when you lift it up with your fingers at the C.G. location.

☞ Once you have flown and become familiar with the flight characteristics of the airplane, the C.G. can be moved fore or aft within the C.G. range to change the flight performance. Moving the C.G. back will cause the airplane to be more responsive, but less stable. Moving the C.G. forward will cause the airplane to be more stable, but less responsive.

**Do not fly the airplane beyond the recommended balance range or an uncontrollable crash could result!**

## SECTION 22: LATERAL BALANCING THE DRAGON LADY 60 ARF

---

☞ Lateral balancing will make the airplane easier to trim and will make it track straighter in the air. It is strongly recommended.

- ❑ Install the wing onto the fuselage. Turn the airplane upside down and tie one length of string to the propeller shaft and one length of string to the tail wheel wire.
- ❑ With someone helping you, carefully lift the airplane up by the two pieces of string. Watch how the wing reacts. If one side of the wing drops, that side is heavier than the other. To correct this condition, stick a small piece of self-adhesive lead weight to the bottom of the lighter wing half (the one that doesn't drop).
- ❑ Repeat the procedure a couple of more times to double-check your findings. When done properly the wing should stay level when you lift up the airplane.

## SECTION 23: CONTROL THROWS

---

We recommend setting up the Dragon Lady 60 ARF using the control throws listed below. These control throws are suggested for initial test-flying because they will allow the airplane to fly smoother and make it easier to control.

### TEST-FLYING

<b>Ailerons:</b>	<b>3/8" Up</b>	<b>3/8" Down</b>
<b>Elevator:</b>	<b>1/2" Up</b>	<b>1/2" Down</b>
<b>Rudder:</b>	<b>3/4" Right</b>	<b>3/4" Left</b>

☞ When measuring the control throws, measure from the widest point of the control surfaces.

#### **VERY IMPORTANT!**

After you are finished adjusting the pushrods and control throws, we strongly suggest cutting 1/4" lengths of the clear tubing provided and sliding one piece over each clevis. The tubing will prevent the clevises from popping open during flight.

Once you're familiar with the flight characteristics of the airplane, you might want to increase the control throws to the aerobatic flying settings listed below. These control throws will make the airplane more responsive and allow you to do most aerobatics with ease.

### AEROBATIC FLYING

<b>Ailerons:</b>	<b>5/8" Up</b>	<b>5/8" Down</b>
<b>Elevator:</b>	<b>3/4" Up</b>	<b>3/4" Down</b>
<b>Rudder:</b>	<b>1-1/4" Right</b>	<b>1-1/4" Left</b>

We do not suggest increasing the control throws beyond the recommended Aerobatic Flying settings unless you are a very proficient flyer. Higher control throws will cause the airplane to be extremely control-sensitive and result in a possible crash if you are not careful.

## SECTION 24: PREFLIGHT CHECK & SAFETY

---

- Completely charge the transmitter and receiver batteries before your first day of flying.
- Check every bolt and every glue joint in the airplane to ensure that everything is tight and well-bonded. This should include all of the control surface hinges as well.
- Double-check that you've installed and tightened all of the servo horn retaining screws.
- Double-check that the receiver and battery are properly secured in the fuselage. There's nothing worse than the battery pack coming loose during a violent aerobatic maneuver.
- Double-check the balance of the airplane. **Do this with the fuel tank empty.**
- Check the control surfaces. They should all move in the correct direction and not bind.
- Make sure that you've installed 1/4" long pieces of clear tubing over the clevises to prevent any chance of them opening during flight.
- If your radio transmitter is equipped with dual rate switches, double-check that they are on the low-rate setting for your first few flights.
- Check to ensure that all of the control surfaces are moving the proper amount in both low and high rate settings.
- Check the receiver antenna. It should be fully extended and not coiled up inside the fuselage.
- Properly balance the propeller. A propeller that is out of balance will cause excessive vibration, which could lead to engine and/or airframe failure, and it will reduce engine efficiency and power.

**The following are our general guidelines for your safety and the safety of others. Please read and understand these safety guidelines before going out to the flying field for the first time.**

- Do not test-fly your model for the first time without first having it safety-checked by an experienced modeler.
- Do not fly your model higher than approximately 400 feet within 3 miles of an airport without having an observer with you. The observer should tell you about any full-size aircraft in your vicinity and you should always give the right-of-way to full-scale aircraft.
- When flying at a flying field with established rules, you should abide by those rules. You should not deliberately fly your model in a reckless and/or dangerous manner.
- While flying, you should not deliberately fly behind the flight line. If your model should inadvertently fly behind the flight line, you should change course immediately.
- You should complete a successful range check of your radio equipment prior to each new day of flying, or prior to the first flight of a new or repaired model.
- You should perform your initial turn after take-off away from the flightline and/or spectator area.
- You should not knowingly operate your R/C radio system within 3 miles of a preexisting model club flying field without a frequency sharing agreement with that club.

## SECTION 25: FLYING THE DRAGON LADY 60 ARF

---

The Dragon Lady 60 ARF is designed for those pilots who are experienced at flying sport models. It is not a trainer. If you do not feel comfortable about test-flying the airplane, don't hesitate to ask someone more experienced for help.

When set up for test-flying, the Dragon Lady 60 is much like flying any other sport aerobatic airplane. It's a nimble flyer that has a low wing loading. This makes it predictable during slow flight and landing. For general sport flying, we recommend you use the "Test-Flying" control throws. For doing aerobatics we suggest using the "Aerobatic Flying" control throws.

### WARNING

If you've chosen to use one of the larger, more powerful engines, your Dragon Lady 60 will have a very high power-to-weight ratio. This high power-to-weight ratio can result in control surface flutter if you are not careful. To prevent any chance of control surface flutter, always reduce engine power during down-leg maneuvers. Never fly the airplane at full throttle in a downward attitude. Doing so can over-speed the airplane and cause control surface flutter, which can quickly lead to airframe damage and/or failure.

### TAKE-OFF

First, it's important to let the airplane get up to flying speed before lifting off the ground. Lifting the airplane off the ground too fast will cause the airplane to stall and crash. You should allow the airplane to roll out until the tail is completely off the ground and flying, and then gently pull the airplane off the ground and into a shallow climb.

Because of the torque of the engine, the airplane will have a natural tendency to pull to the left when it is accelerating down the runway. You will need to compensate for this by applying and holding right rudder during the takeoff roll. Once the airplane lifts off the ground, you can release the right rudder. Because of the wide landing gear stance and long tail moment you will find the ground handling of the Dragon Lady 60 very smooth and predictable.

### IN THE AIR

In the air the Dragon Lady 60 is as smooth and docile or as wild and aerobatic as you want it to be. With the control throws set to the "Test-Flying" settings, the airplane is smooth throughout the entire flight envelope. Most flyers interested in sport-flying will probably want to keep the control throws set to the "Test-Flying" settings for most maneuvers.

Setting the control throws to the "Aerobatic Flying" settings opens up a whole new dimension to the airplane. With these settings and a powerful engine the airplane becomes extremely responsive in all attitudes, and is capable of nearly flying out of sight vertically. We suggest that if you use the "Aerobatic Flying" settings, you make these your "high rates" and make the "Test-Flying" settings your "low rates." This way, for take-off, general flying and landing you can use low rates, and for aerobatic flying you can use high rates. If you use a computer-style radio system, you might want to consider adding exponential on the rudder, aileron and elevator controls while using the "Aerobatic Flying" control throws. This will make the airplane less "twitchy" while using the higher control throws.

### LANDING

We've designed the Dragon Lady 60 so it will slow down nicely for landing and still be responsive to control inputs. Because of this design, landings are quite slow and predictable. There is no tendency to tip stall, but we do recommend that you land with a small amount of power. It's not good practice to just chop the power and dive the airplane to the runway.

On your initial upwind leg, reduce power and allow the airplane to begin slowing down. Follow your normal landing procedure, allowing the airplane to gradually lose altitude and speed. When turning onto final approach the airplane should have a slightly nose-up attitude and you should be carrying a small amount of power to control your descent rate.

Just before touch-down, reduce power to idle and let the airplane settle onto the main gear. If you flair too much or try for a three point landing, the airplane will have a tendency to balloon up and possibly stall if it's too slow. As always, when landing be careful not to over-control. Over-controlling leads to excessive oscillations which don't make for good landings.

## SECTION 26: DRAGON LADY 60 ARF TRIMMING CHART

After you have test-flown and done the initial trim changes to the airplane, use this trimming chart to begin trimming your airplane. Following and adhering to this chart will result in the ability to diagnose trim problems and correct those problems using the simple adjustments shown below. Making these observations and related corrections will result in a straighter and truer flying airplane.

TRIM FEATURE	MANEUVER	OBSERVATION	CORRECTION
Control Centering	Fly general circles and random maneuvers	Try for hands off straight and level flight	Readjust linkages so the transmitter trim levers are centered
Control Throws	Fly random maneuvers	A) Controls are too sensitive or airplane feels "jerky" B) Controls are not sensitive enough or airplane feels "mushy"	If A) Adjust linkages to reduce control throws If B) Adjust linkages to increase control throws
Engine Thrust Angle*	From straight and level flight, quickly chop the throttle for a short distance	A) Airplane continues in a level attitude for a short distance B) Airplane pitches nose up C) Airplane pitches nose down	If A) Engine thrust angle is correct If B) Decrease engine down thrust If C) Increase engine down thrust
Center of Gravity	From level flight, roll to a 45° bank and neutralize the controls	A) Airplane continues in the bank for a short distance B) Nose pitches up C) Nose pitches down	If A) Center of gravity is correct If B) Add nose weight If C) Remove nose weight or add tail weight
Yaw**	Into the wind, perform inside loops using only elevator. Repeat test, performing outside loops from an inverted entry	A) Wing is level throughout B) Airplane yaws to right in both inside and outside loops C) Airplane yaws to left in both inside and outside loops D) Airplane yaws to the right in inside loops and yaws to the left in outside loops E) Airplane yaws to the left in inside loops and yaws to the right in outside loops	If A) Trim settings are correct If B) Add left rudder trim If C) Add right rudder trim If D) Add left aileron trim If E) Add right aileron trim
Lateral Balance**	Into the wind, perform tight inside loops using only elevator	A) Wing is level and airplane falls to either side B) Airplane falls off to the left. Worsens as loops tighten C) Airplane falls off to the right. Worsens as loops tighten	If A) Lateral balance is correct If B) Add weight to right wing tip If C) Add weight to left wing tip
Aileron Control System	With the wing level, pull to a vertical climb and neutralize the controls	A) Climb continues along the same path B) Nose tends to go toward an inside loop C) Nose tends to go toward an outside loop	If A) Trim settings are correct If B) Raise both ailerons very slightly If C) Lower both ailerons very slightly

\*Engine thrust angle and center of gravity interact. Check both.

\*\*Yaw and lateral balance produce similar symptoms. Note that the fin may be crooked. Right and left references are as if you were in the cockpit.

## SECTION 27: OPTIONAL REAR-MOUNTED ELEVATOR & RUDDER SERVOS

This section describes installation of the optional rear-mounted elevator and rudder servos. As stated previously, we suggest installing the elevator and rudder servos in the back of the fuselage if you will be using larger, heavier engines. This will help balance the airplane without having to add extra weight to the tail.

- ❑ Remove the covering material from over the two precut servo mounting holes in the fuselage sides. The elevator servo mounting hole is located in the **right side** of the fuselage, 7-1/2" in front of the rudder hinge line and 1-3/4" up from the bottom of the fuselage. The rudder servo mounting hole is located in the **left side** of the fuselage, 6" in front of the rudder hinge line and 1" up from the bottom of the fuselage.



- ❑ Install the elevator and rudder servos into the servo mounting holes, making sure the servo output shafts are toward the **back** of the fuselage.

**IMPORTANT** When installing the elevator servo, carefully push the two nylon pushrod housings up while sliding the servo into place.

☞ To make it easier to install the servo mounting screws, first drill 1/16" pilot holes through the fuselage sides.

- ❑ Use a couple of pieces of masking tape to hold the elevator centered.



- ❑ Position one nylon control horn onto the bottom of the elevator. The centerline of the control horn should be 5/8" out from the side of the fuselage and the base of the control horn should be parallel to the elevator hinge line. Make sure that the clevis attachment holes are directly over the hinge line, too.

- ❑ Mark the positions of the control horn mounting screws, then remove the control horn and set it aside.
- ❑ Drill the holes through the elevator for the mounting screws using a 5/64" diameter drill bit.
- ❑ Install the control horn and backplate using two 2mm x 20mm machine screws, being careful not to overtighten them.
- ❑ Thread one clevis onto one 31" long threaded pushrod wire and snap it into the **third hole** out from the base of the control horn.

☞ Hold the pushrod wire with a pair of pliers to prevent it from turning while installing the clevis.

- ❑ Using a modeling knife, carefully cut away all but one arm from a large "4-point" servo horn.
- ❑ Enlarge the **third hole** out from the center of the servo arm using a 5/64" diameter drill bit.

- ❑ Connect your radio system and plug the elevator servo into the receiver. Double-check that the elevator trim lever on your transmitter is centered.
- ❑ Attach the servo horn to the servo, making sure it's centered and points **up** toward the **top** of the fuselage.
- ❑ With the elevator and the servo horn centered, draw a mark on the elevator pushrod wire where it crosses the **third hole** out from the center of the servo horn.
- ❑ Using a pair of pliers, carefully bend the pushrod wire at a 90° angle (at the mark you drew) and cut off the excess, leaving 5/16" of wire beyond the bend.



- ❑ Secure the pushrod wire to the servo horn using one nylon 90° snap keeper.
- ❑ Install and tighten the servo horn retaining screw to secure the servo horn to the servo.

- ❑ Repeat the same procedures to install the rudder pushrod assembly. The setup is exactly the same, the only difference being that the centerline of the rudder control horn should be 1-1/4" up from the bottom of the rudder.

# PRODUCT EVALUATION SHEET

Telling us what you like and don't like determines what model kits we make and how we make them. We would appreciate it if you would take a few minutes of your time to answer the following questions about this kit and your modeling interests. Simply fold this form on the dotted lines, seal with tape and mail it to us. *Do not use staples and make sure our address faces out.*

Global Hobby Distributors will not disclose the information it collects to outside parties. Global Hobby Distributors does not sell, trade, or rent your personal information to others. Your privacy is important to us.

Cut Along Dotted Line

1) Kit: **Modeltech Dragon Lady 60 ARF # 123761**

- 2) Where did you learn about this kit?
- |                                       |                                 |
|---------------------------------------|---------------------------------|
| <input type="checkbox"/> Magazine Ads | <input type="checkbox"/> Friend |
| <input type="checkbox"/> Hobby Shop   | <input type="checkbox"/> Other  |
| <input type="checkbox"/> Internet     |                                 |

- 3) What influenced you the most to buy this kit?
- |                                         |                                  |
|-----------------------------------------|----------------------------------|
| <input type="checkbox"/> Magazine Ads   | <input type="checkbox"/> Price   |
| <input type="checkbox"/> Type of Model  | <input type="checkbox"/> Box Art |
| <input type="checkbox"/> Recommendation | <input type="checkbox"/> Other   |
| <input type="checkbox"/> Internet       |                                  |

- 4) Did you have any trouble understanding the written instructions? If yes, please explain.
- Yes                       No

\_\_\_\_\_

\_\_\_\_\_

\_\_\_\_\_

- 5) Did you have any trouble understanding any of the photographs? If yes, please explain.
- Yes                       No

\_\_\_\_\_

\_\_\_\_\_

\_\_\_\_\_

- 6) Were any of the kit parts:
- |                                  |                                      |
|----------------------------------|--------------------------------------|
| <input type="checkbox"/> Damaged | <input type="checkbox"/> Wrong Size  |
| <input type="checkbox"/> Missing | <input type="checkbox"/> Wrong Shape |

If you checked any of the boxes above, did you contact our Customer Service Department to resolve the problem?

- Yes                       No

- 7) Was any of the assembly difficult for you? If yes, please explain.

Yes                       No

\_\_\_\_\_

\_\_\_\_\_

\_\_\_\_\_

- 8) What did you like most about this kit?
- |                                            |                                    |
|--------------------------------------------|------------------------------------|
| <input type="checkbox"/> Assembly Manual   | <input type="checkbox"/> Parts Fit |
| <input type="checkbox"/> Hardware Supplied | <input type="checkbox"/> Price     |
| <input type="checkbox"/> Other             |                                    |

\_\_\_\_\_

\_\_\_\_\_

\_\_\_\_\_

- 9) What did you like least about this kit?
- |                                            |                                    |
|--------------------------------------------|------------------------------------|
| <input type="checkbox"/> Assembly Manual   | <input type="checkbox"/> Parts Fit |
| <input type="checkbox"/> Hardware Supplied | <input type="checkbox"/> Price     |
| <input type="checkbox"/> Other             |                                    |

\_\_\_\_\_

\_\_\_\_\_

\_\_\_\_\_

- 10) Are you satisfied with the finished model? If no, please explain.

Yes                       No

\_\_\_\_\_

\_\_\_\_\_

\_\_\_\_\_

- 11) How does this kit compare to similar kits by other manufacturers?

- Better                       As Good

What is Your Age Group:

- 10 & Under     11 - 20     21 - 30     31 - 40     41 - 50     51 - 60     61 - 70     71 +

How Many Years Have You Been in the Hobby?

- Less than 1     2 - 4     5 - 7     8 - 10     11 - 15     16 - 20     20 or More

How Many Models Have You Purchased In the Last Year?

- 0 - 1               2 - 4               5 - 7               8 - 10               10 or More

Please List any Other Modeling Interests or any Additional Information about This Product: \_\_\_\_\_

\_\_\_\_\_

\_\_\_\_\_

\_\_\_\_\_

Fold along dotted line

---

---

---

(Return Address Here)

Post Office will  
not deliver  
without proper  
postage

Global Hobby Distributors  
**Attn: Global Services**  
18480 Bandilier Circle  
Fountain Valley CA 92728-8610

Fold along dotted line