

US Patent # 6216440

Copyright © JetCat USA
October 15, 2010



JetCat RX Turbines with V10 ECU



JetCat USA, LLC

4250 Aerotech Center Way, Building G
Paso Robles, CA 93446
(805) 226-8700 Voice
(805) 226-8742 FAX
www.jetcatusa.com

Manufactured in Germany by
Büro CAT, M. Zipperer GmbH, Etzenbach 16, 79 129 Staufien
Tel: + 49 (0) 76 36-78 03-0
Fax: + 49 (0) 76 36-78 03-45
Internet: www.jetcat.de

JetCat USA Three Year Limited Warranty.

JetCat USA, LLC, a Limited Liability Company, ("JetCat USA") warrants that this MINATURE TURBOJET ENGINE for model aircraft, cars or boats ("Model Engine") enclosed with this warranty statement is free from defects in materials and workmanship during normal usage, according to the following terms and conditions.

- 1) The limited warranty extends to the original purchaser ("Buyer") of the Model Engine and is assignable or transferable to any subsequent purchaser / end-user.
- 2) Upon request from JetCat USA, the Buyer must prove the date of the original purchase of the Model Engine by a dated bill of sale or dated itemized receipt.
- 3) Warranty coverage begins the day you buy the Model Engine. For 3 (three) years all labor and parts except for the glow plug and battery will be repaired or replaced free of charge. All parts, including repaired and replaced parts are covered for the original warranty period. When the warranty on the Model Engine expires, the warranty on all replaced and repaired parts also expires.
- 4) During the limited warranty period, JetCat USA will repair or replace, at JetCat USA's option, any defective parts with new or factory rebuilt replacement items if such repair or replacement is needed because of Model Engine malfunction or failure during normal usage. No charge will be made to the Buyer for any such parts. JetCat USA will also pay for the labor charges incurred by JetCat USA in repairing or replacing the defective parts. The limited warranty does not cover defects in appearance. JetCat USA shall not be liable for any other losses or damages.
- 5) The Buyer must operate and maintain the Model Engines in accordance to the Model Engine manual. The Model Engine must be returned to JetCat USA for maintenance on or before the TBO (Time Before Overhaul) interval of every 25 hours. If Buyer fails to return the Model Engine within the TBO interval, any damaged parts affected by this negligence will be subject to additional repair costs.
- 6) The Buyer shall have no coverage or benefits under this limited warranty if any of the following conditions are applicable
 - a) The Model Engine has been subject to abnormal use, abnormal conditions, improper storage, unauthorized modifications, unauthorized repair, misuse, neglect, abuse, accident, alteration, improper installation or other acts which are not the fault of JetCat USA, including damage caused by shipping.
 - b) The Model Engine has been damaged from external causes such as crash damage, foreign object damage, weather, Act of God, improper electrical connections, or connections to other products not recommend for interconnection by JetCat USA.
 - c) The Model Engine is operated for commercial or institutional use.
 - d) The Model Engine serial number has been deliberately removed, defaced or altered.
- 7) If a problem develops during the limited warranty period, the Buyer shall take the following step-by-step procedure:
 - a) The Buyer shall ship the Model Engine prepaid and insured to JetCat USA.
 - b) The Buyer shall include a return address, daytime phone number and / or FAX number, complete description of the problem and proof of purchase.
 - c) The Buyer will be billed for any parts or labor charges not covered by this limited warranty.
 - d) If the Model Engine is returned to JetCat USA during the limited warranty period, but the problem with the Model Engine is not covered under the terms and conditions of this limited warranty, the Buyer will be notified and given an estimate of the charges the Buyer must pay to have the Model Engine repaired, with all shipping charges billed to the Buyer. If the estimate is refused, the Model Engine will be returned freight collect. If the Model Engine is returned to JetCat USA after the expiration of the limited warranty period, JetCat USA's normal service policies shall apply and the Buyer will be responsible for all shipping charges.
- 8) The Buyer must bear the cost of shipping the Model Engine to JetCat USA in Paso Robles, California. JetCat USA shall bear the cost of shipping the Model Engine back to the Buyer, within the continental United States, after the completion of service under this limited warranty. The Buyer must pay for any other shipping charges.
- 9) The Model Engine consists of newly assembled equipment that may contain used components that have been reprocessed to allow machine compliance with Model Engine performance and reliability specifications.
- 10) JetCat USA shall not be liable for delay in rendering service under the limited warranty, or loss of use during the period that the Model Engine is being repaired.
- 11) JetCat USA neither assumes nor authorizes any other person or entity to assume for it any other obligation or liability beyond that is expressly provided for in this limited warranty.
- 12) This is the entire warranty between JetCat USA and the Buyer, and supersedes all prior and contemporaneous agreements or understandings, oral or written, and all communications relating to the Model Engine, and no representation, promise or condition not contained herein shall modify these terms.
- 13) Buyer must fully accept all conditions of the PURCHASE AGREEMENT, FULL ASSUMPTION OF LIABILITY AND INDEMNITY AGREEMENT
- 14) If the Buyer is not prepared to fully accept the liability associated with the use of this Model Engine, the Buyer is advised to return this Model Engine immediately in new and unused condition to the place of purchase.
- 15) This limited warranty allocates the risk of failure of the Model Engine between the Buyer and JetCat USA. The allocation is recognized by the Buyer and is reflected in the purchase price of the Model Engine.
- 16) Questions concerning the warranty may be directed to:

JetCat USA, LLC
4250 Aerotech Center Way, Building G
Paso Robles, CA 93446

805-226-8700 Voice
805-226-8742 FAX
www.jetcatusa.com

PURCHASE AGREEMENT, FULL ASSUMPTION OF LIABILITY AND INDEMNITY AGREEMENT

Buyer purchases from JetCat USA, a Limited Liability Company ("JetCat USA") or from one of JetCat USA's authorized dealers, a MINIATURE TURBOJET ENGINE for model aircraft, cars or boats ("Model Engine") for the invoice price, accompanying this sale, and Buyer and JetCat USA agree to all of the following terms and conditions:

1. Buyer's Representations. Buyer represents that he/she is very experienced in model airplane operation, and that all of the information set forth in the Purchase Application is true and correct. JetCat USA relies on such representations, and would not enter into this sale but for these representations.

2. Buyer's Acknowledgment of Risks and Dangers. Buyer recognizes that operation of the Model Engine may be dangerous, and that under certain circumstances, its handling will be dangerous. As set forth in Paragraph 3 below, Buyer accepts full responsibility for all of these risks and waives all liability as against JetCat USA.

(a) Buyer's Acknowledgment of Danger. Buyer expressly acknowledges that use of the Model Engine is dangerous if improperly handled, and could inflict injury if attempts are made to handle it properly, if the user does not fully acquaint himself/herself with the Model Engine's operation procedures. The Model Engine may cause burns to the user, or the user's assistant, particularly in the start-up procedure, and Buyer agrees to use extreme caution. The Model Engine exhaust is extremely hot, and will burn someone or something placed directly behind the exhaust tube. Highly flammable liquid is used to operate the Model Engine, and it or its fumes will ignite easily and flare up rapidly. The Model Engine itself remains extremely hot, after it is shut off, and requires a cooling down period. Improper use of the Model Engine, or failure to follow Academy of Model Aeronautics ("AMA") guidelines and rules will result in injury to the user, the user's assistant, or bystanders. Operation of the Model Engine in any location other than an approved location, and under safe circumstances could lead to injury to bystanders. A risk exists from explosion, in the event of tampering, modifications leading to over-speed or extreme metal fatigue.

(b) Buyer's Obligation to Become Fully Acquainted With Operation Procedure. Buyer acknowledges receipt of operating instructions for the Model Engine which depicts its handling and operation. Buyer agrees to thoroughly acquaint himself/herself with these materials, and to require his/her assistant to become equally familiar with them. Buyer expressly agrees not to allow any person to assist in the start-up procedure of the Model Engine, who has not become thoroughly familiar with these materials.

(c) Agreement to Use Qualified Assistant in Start-Up Procedure. Buyer acknowledges that the start-up procedure for the Model Engine cannot be safely done, without an assistant. Buyer expressly agrees to use an assistant, who is thoroughly familiar with the Model Engine and its operation as set forth above, on each occasion when the Model Engine is started up.

(d) Warning to Bystanders. Buyer acknowledges that injury or burns to bystanders could occur, during the start-up procedure or when operating the Model Engine. Buyer expressly agrees to take all steps necessary to assure that no bystander will be in a position to receive injuries during the start-up procedure, or while the Model Engine is running.

3. Full Assumption of Liability; Waiver and Release of JetCat USA. Buyer assumes all risk of injury, harm and damage, of every nature whatsoever, to himself/herself and his/her property. Buyer fully and completely waives and releases any and all claims which he/she might have at any time arising out of the purchase, handling, or operation of the Model Engine. This assumption, waiver and release is complete, full, and comprehensive.

(a) Release Even If JetCat USA Is Negligent. The waiver and release contained herein releases JetCat USA from all conduct, no matter how it could be characterized or alleged. JetCat USA shall not be liable for its own negligence, whether active, passive, primary, or secondary. JetCat USA shall not be liable for its sole negligence. JetCat USA shall not be liable for its willful misconduct. JetCat USA shall not be liable based on any theory in strict liability in tort. JetCat USA shall not be liable for any alleged breach of warranty, whether express or implied, of any nature whatsoever, whether a warranty of fitness for a particular use, merchantability, or otherwise. There is no warranty of merchantability; there is no warranty of fitness for a particular purpose; and there are no warranties which extend beyond the description on the face hereof or JetCat USA's One Year Limited Warranty.

(b) Waiver Effective for All Time. The waiver and release contained herein is effective, without regard to the passage of time. It is effective indefinitely. It will not be changed by any modification to the Model Engine, to any later sale, or other changes in circumstances.

(c) Release Extends to JetCat USA and All Its Associates. The waiver and release contained herein protects JetCat USA, and all of its employees, officers, principals, owners, designers, and agents ("Associates").

(d) Waiver of Civil Code Section 1542. Buyer acknowledges the existence of, and fully and completely waives the provisions of California Civil Code Section 1542, which provides:

"A general release does not extend to claims which the creditor does not know or suspect to exist in his favor at the time of executing the release, which if known by him must have materially affected his settlement with the debtor."

4. No Modifications to Model Engine. Buyer agrees to make no modifications of any kind to the Model Engine. This Agreement pertains to the entire life of the Model Engine.

5. Sale By Buyer to Other Party. Buyer agrees to fully inform any person to whom he/she sells or transfers the Model Engine, concerning the handling, use, and operation of the Model Engine, and agrees to give all operating instructions to such person, at or before the time of sale or transfer. The indemnity and hold harmless agreement contained in Paragraph 3 continues in effect, following such sale or transfer.

6. Severability. In the event any clause, provision, or term of this Agreement is held to be ineffective, void or otherwise unenforceable for any reason, that clause, provision, or term shall be severed from this Agreement, and the Agreement shall otherwise remain binding and effective. If any portion of Paragraph 3 is found to be unenforceable, then the parties agree that the fullest and most complete waiver and release which is permitted by law, shall be effective.

7. California Law Applicable. The law of the State of California shall apply to any and all controversies which may arise out of or relate to this Agreement, the sale of the Model Engine, or its ownership, use, or operation.

8. Arbitration. ANY CONTROVERSY OR CLAIM ARISING OUT OF OR RELATING TO THIS AGREEMENT, OR THE BREACH THEREOF, OR THE OWNERSHIP, USE, OR OPERATION OF THE MODEL ENGINE, SHALL BE SETTLED BY ARBITRATION ADMINISTERED BY THE JUDICIAL ARBITRATION AND MEDIATION SERVICE/ENDISPUTE, AT ITS LOS ANGELES OFFICE, UNDER ITS THEN APPLICABLE RULES AND PROCEDURES. THE ARBITRATION SHALL BE BINDING, AND JUDGMENT ON THE AWARD RENDERED BY THE ARBITRATOR MAY BE ENTERED IN ANY COURT HAVING JURISDICTION. BUYER EXPRESSLY ACKNOWLEDGES AND WAIVES THE RIGHT TO FILE A LAWSUIT IN A COURT OF LAW, TO HAVE THE MATTER DETERMINED BY A JURY, AND TO APPEAL. BUYER'S AGREEMENT TO THIS ARBITRATION PROVISION IS VOLUNTARY. THE PARTIES HAVE READ AND UNDERSTAND THE FOREGOING AND AGREE TO SUBMIT DISPUTES ARISING OUT OF ALL MATTERS TO NEUTRAL ARBITRATION.

9. This Document Is the Full Expression of Parties' Agreement. This Agreement contains the full and complete agreement of the parties. There is no representation, term, or provision which is outside this Agreement. Any and all discussions, oral agreements, and representations are merged into this single written Agreement. This Agreement cannot be modified or amended in any way, except by written Amendment, signed by the parties.

10. Paragraph Headings Not Controlling. The heading to any paragraph, or subparagraph of this Agreement, shall not be dispositive, but may be used to interpret the parties' intentions.

11. No Interpretation of Agreement Against Either Party. Buyer understands and expressly acknowledges that he/she has the right to have an attorney read and review this Agreement, before execution. This Agreement shall not be interpreted against either party, but shall be interpreted as if it was drafted mutually by the parties.

12) If the Buyer is not prepared to fully accept the PURCHASE AGREEMENT, FULL ASSUMPTION OF LIABILITY AND INDEMNITY AGREEMENT, the Buyer is advised to return this Model Engine immediately in new and unused condition to the place of purchase.

Contents

INTRODUCTION	7
SAFETY, MEANING OF SYMBOLS	8
SAFETY PRECAUTIONS	8
QUICK START SECTION FOR RX TURBINES WITH V10 ECU	10
IDENTIFY COMPONENTS	10
MOUNTING THE TURBINE SUPPORT EQUIPMENT	11
MOUNTING THE TURBINE	11
TURBINE SIDE VIEW / THRUST TUBE	12
INLET PROTECTION	12
CONNECTIONS	13
COMPLETE SYSTEM CONNECTION DIAGRAM	13
COMPLETE SYSTEM CONNECTIONS PHOTO	14
FUEL CONNECTIONS	15
HOPPER TANK - UAT.....	15
ELECTRICAL CONNECTION	16
INTERCONNECTIONS.....	16
POWER	17
BATTERY BALANCE ADAPTER	17
GROUND SUPPORT UNIT (GSU)	18
GSU CONTROL PANEL DESCRIPTIONS	18
GSU SWITCH DESCRIPTIONS	19
THE LED I/O BOARD	19
DESCRIPTION OF LEDs ON THE GSU AND LED BOARD	19
JETCAT V10 ECU	20
SWITCHING ON THE ECU	20
SINGLE OR TWO CHANNEL OPERATION?	21
HOW TO SET YOUR ECU FOR SINGLE CHANNEL OPERATION.....	21
SETUP FAILSAFE MODE	21
SETTING THE FAILSAFE	21
“LEARN R/C”. TEACH THE ECU TO THE R/C SYSTEM	22
VERIFY FAILSAFE PROGRAMING.....	25
PREPARING FUEL AND FUEL SYSTEM	25
FUELING ON BOARD TANKS	25
PRIME THE PUMP AND SYSTEM	26
RUNNING THE TURBINE FOR THE FIRST TIME	26
THE CHECKLIST	26
BEFORE RUNNING THE TURBINE	26
AFTER STOPPING THE TURBINE.....	26
STARTING AND STOPPING THE TURBINE	26
AFTER THE START PROCESS IS INITIATED, THE FOLLOWING OCCURS:	27
AUTOMATIC COOLING PROCESS	28

GSU (RUN MENU DEFAULT) DISPLAY SYMBOLS.....	28
INITIAL DEFAULT DISPLAY SCREEN AFTER POWER UP.....	28
AFTER POWER UP – “ERROR CONDITION” DISPLAY SCREEN.....	28
TURBINE STARTING DISPLAY SCREEN.....	29
TURBINE RUNNING DISPLAY SCREEN.....	29
TURBINE RUNNING STATES.....	29
EXPLANATION OF THE TURBINE STATES	30
TROUBLESHOOTING	32
MOST FREQUENT ERRORS. CAUSE AND REMEDY:.....	32
REASON FOR AN UNEXPECTED SHUT-DOWN	33
MANUAL ADVANCED SECTION.....	34
JETCAT ECU FEATURES VERSION 10.00.....	34

Introduction

Welcome to the Jet Age of model aircraft! **JetCat** is pleased to sell, support and service the **JetCat** turbine engine and greatly appreciates your purchase. We hope the **JetCat turbine** brings you many days of pleasurable flying.

Obviously, model turbine aviation - despite all the apparent fun involved - is serious business. The **JetCat turbine** has undergone extensive testing and redesign, in order to ensure it is a safe and reliable model turbine; however, it is **not** a recommended power source for the average model builder. It requires a good background in model flying and a working understanding of the principles of turbine engines, along with a disciplined commitment to correct and safe operation, in accordance with these instructions. To begin, read this manual thoroughly. Develop an overall impression of the turbine and its operating procedures, measuring equipment and accessories. Study the material step-by-step and ascertain how to install, operate and maintain your turbine engine. If you are unsure about anything, re-read it again.

DO NOT OPERATE THE *JetCat turbine* BEFORE YOU HAVE READ THE MANUAL AND FULLY UNDERSTAND EVERY PROCEDURAL DETAIL





Should you still have doubts or questions, do not hesitate to contact **JetCat** for further assistance.

The **JetCat** model jet turbine closely functions like a full size jet turbine. A centrifugal compressor compresses the incoming air which is mixed in the combustion chamber with fuel (jet fuel / kerosene) and ignited. The result is a rapidly expanding volume of gas that drives an axial turbine wheel. The gas exiting the exhaust cone produces the required thrust for the jet model. To start the turbine, an electric motor is mounted on the front of the turbine. During startup to preheat the combustion chamber was formerly done with an auxiliary gas (propane / butane). However, the new **JetCat** RX series turbines utilize an internal kerosene start system using only a single fuel (kerosene) for starting and running. This single fuel operation is a more appropriate and simpler way of starting instead of the using a glow plug and an auxiliary fuel. RX turbines have the fuel control valves mounted internally for a very simple single fuel connection. The compressor is machined from high strength aluminum alloy using modern CNC technology. This guarantees even higher speed stability and an incredibly fast and precise acceleration.







The **JetCat** V10 ECU is a sophisticated on-board electronics that controls and monitors all the operating parameters. The parameters are displayed on the included hand held terminal (GSU) and several can be modified by the user for optimizing different installations. The power supply for all on board components, including the internal starting plug, is supplied via a 9.9V lithium iron phosphate battery.







The complete turbine kit contains all components required for operation and is a “plug and play” configuration.

Safety, meaning of symbols

	ATTENTION! This symbol highlights the following points which must be strictly observed by the user! Any violation of the corresponding restrictions may impair the safe operation and the safety of the user.
	ATTENTION! This symbol highlights restrictions which must be strictly observed by the user! Any violation of the corresponding restrictions may impair the functional efficiency and severely compromise user safety.
	ATTENTION! This symbol highlights information that should be heeded by the user to ensure safe operation of the device
	ATTENTION! Fire or explosion hazard!
	ATTENTION! This symbol warns of hot objects and surfaces. Any violation of the corresponding restrictions may affect the health of the user.

Safety Precautions

	WARNING! Errors and / or defects in the construction or operation of a jet model can lead to personal injury or even death.						
	ATTENTION! Before you put a model aircraft in operation, you must learn about the law. Legally, a model aircraft is a real aircraft and is subject to applicable laws which must be strictly adhered to. The rules of other countries are to be observed accordingly.						
	WARNING! It is your responsibility to protect others from injury. The minimum operating distance of residential areas to ensure the safety of people, animals and buildings must be at least 1 mile. Never operate model turbine jet aircraft in or around residential or heavily populated areas. Keep a safe distance away from power lines. Do not fly the model in bad weather with low clouds or fog. Never fly into direct sunlight, otherwise you might lose sight of the model. To avoid collisions with manned or unmanned aircraft, land your model immediately if a plane approaches. Persons or animals must comply with the following minimum safety distances from a turbine model: <table style="margin-left: auto; margin-right: auto;"> <tr> <td>In front of the turbine</td> <td>= 15 feet</td> </tr> <tr> <td>On the side of the turbine</td> <td>= 25 feet</td> </tr> <tr> <td>Behind the turbine</td> <td>= 15 feet</td> </tr> </table>	In front of the turbine	= 15 feet	On the side of the turbine	= 25 feet	Behind the turbine	= 15 feet
In front of the turbine	= 15 feet						
On the side of the turbine	= 25 feet						
Behind the turbine	= 15 feet						
	WARNING! The construction and operation of the model and / or turbine under the influence of alcohol, drugs, medicines, etc. are strictly forbidden. These activities must take place only in the best physical and mental health condition. This applies to both the operator and any assistants.						
	WARNING! The <i>JetCat</i> model jet turbines were designed exclusively for model aircraft and are NOT suitable for any other purpose. Never use for any other purpose except for the flight of the model. Any other types of uses may result in personal injury or death.						
	WARNING! Any deviations from these instructions or the instructions of the manufacturer, the use of other parts or materials or changes to the system may have an adverse effect on the functionality and reliability of the turbines and therefore must be avoided at all costs.						
	WARNING! The operation of a model jet turbine can only be done under strict accordance of the model, remote control and turbine operation manual. Before flying the model, all control functions and surfaces as well as the range of the remote control system must be checked in the accordance of the manufacture. The checking of these operations must be repeated with a running turbine engine including the remote control system range.						













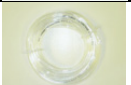

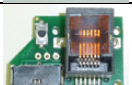
	<p>WARNING! In case of a mishap, fire extinguishers should be on hand at all times. <i>JetCat</i> recommends the CO/2 variety. Powdered extinguishers will corrode the precision components inside the turbine and void your warranty.</p>
	<p>WARNING! When the turbine is running, never place your hands closer than six inches into the area of the intake. An extreme suction which can grasp a hand, fingers or other objects in an instant exists in this area. Always be aware of this source of danger! Prevent foreign materials from entering the intake or exhaust when working with the turbine. Before operation, make sure there are no loose parts or debris near the turbine. Objects being sucked in can cause severe damage. If your installation allows, we highly recommend using a "Jet Net" to protect the intake.</p>
	<p>WARNING! Never run the turbine in a closed room, or an area near any kind of flammable matter. Do not fly turbine-powered aircraft near flammable materials, nor in forested tracts or areas experiencing drought or dryness. Obey all forest fire regulations and warnings by refraining from operating the <i>JetCat</i> turbine in restricted fire zones.</p>
	<p>WARNING! The overflight of people, especially at low altitude, is strictly prohibited</p>
	<p>Attention! Always exercise caution around the hot parts of the turbine, to avoid burns. The outer case at the turbine stage and nozzle reaches 450-600° (Celsius), while the exhaust gas may exceed 800 °C.</p>
	<p>WARNING! Assure that the fuel is mixed with approximately 5% synthetic oil. Use only synthetic turbine oils available at local airport fuel suppliers. Synthetic turbine oils are dangerous and should only be handled as per the manufactures MDS sheets. <i>JetCat</i> has available a compatible oil that is less harmful that also contains an antistatic ingredient. Contact <i>JetCat</i> for more information.</p>
	<p>WARNING! To the avoid hearing damage, always use hearing protection when you are near a running turbine engine!</p>

Quick Start section for RX turbines with V10 ECU

This section covers just the very basics to get your **JetCat** turbine up and running. However, it is not a substitute for reading and understanding the manual in its entirety. There are many great features and options not cover in this section that are fully explained later.

- Identify components
- Mounting turbine support equipment
- Mounting turbine and fitting to tail pipe
- Fuel and electrical connections
- Battery power
- GSU and I/O board
- ECU power, setting failsafe and learn R/C
- Preparing fuel and fuel system
- Starting and stopping the turbine
- Running states
- Troubleshooting

Identify components

1 – Turbine engine		1 – Pump Cable	
1 – GSU, Ground Support Unit (Terminal)		1 – Fuel Line	
1 – ECU, Electronic Control Unit		1 – Fuel Filter	
1 – Mini I/O board		1 – Ballcock Valve	
1 – Pump		1 – 6 to 4mm Nipple, (Brass)	
1 – Battery Pack		1 – Charging Cable	
1 – Turbine Power/Data Cable		1 – Battery Balance Adapter	
1 – I/O Board Flat Cable		1 – Turbine Mount	
1 – GSU Data Cable			

Mounting the turbine support equipment

There are just four main accessory components to decide where and how to mount in your model, (battery, ECU, I/O board and pump). Judge how to position these components within the cable lengths by laying them out in your model approximately where you would like to mount them. Since the components of the new RX series engines are so small, the default cables lengths should work for most installations. If longer cables are needed, consider a battery cable extension with heavy gauge wire as the simplest approach. If your model needs longer cables, call **JetCat** and we can make custom lengths.

1. Battery. Usually the battery will mount in the nose area for balance requirements. When mounting, make sure it is secure but accessible since it is a component you will be removing regularly.
2. ECU should be mounted on a wood plate typically with Velcro. It should also be located in an easy location for removal. Consider applying the Velcro on the opposite side of the “on” switch access hole. See photo.
3. The I/O board should be mounted where the LED indicators will be visible and the data bus jack accessible for plugging in the GSU.
4. Ideally the pump should be mounted inverted using 4/40 screws and nuts through the flange holes (tubes mounted down and electrical connections on top). The pump requires a 1” diameter clearance hole. The pump can also be mounted horizontally with cable ties or clamp. Make sure that the fuel tubes will route so the fuel filter will be easy to access for cleaning. Favor the pump nearer to the UAT hopper tank keeping the inlet tube length as short as possible.

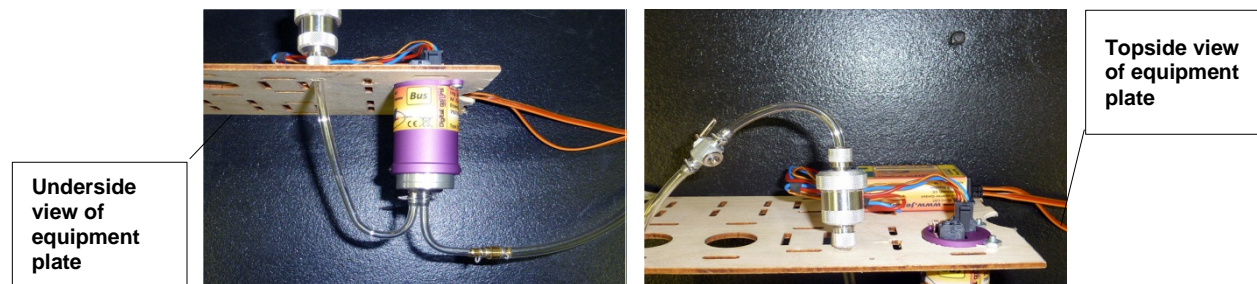
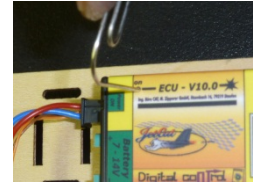

In the above pictures is one example on how to mount the pump. In this case, there was plenty of room under the mounting plate to not pinch the tubes exiting the pump.

Mounting the turbine

A two-piece, aluminum mounting bracket is included with the turbine. Place the bracket around the turbine, with the center plug situated within the slot of the bracket or in the grooved portion of the turbine body depending on turbine type. This will help stabilize the turbine along the thrust axis. Secure the turbine, using four metric mounting screws and lock washers that are provided with brackets. The turbine can be set to any 360 degree rotational position.

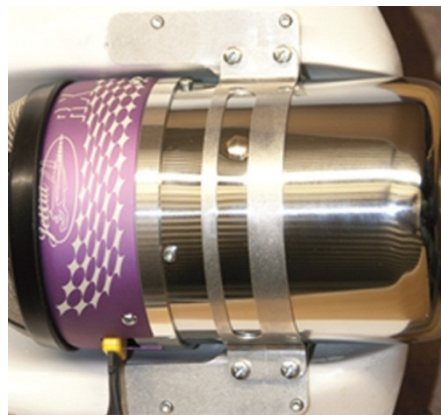

Turbine side view / thrust tube



For internally mounted turbines that do not utilize a bypass, set the ducting inlet $\frac{1}{2}$ to $\frac{3}{4}$ of an inch after the end of the exhaust nozzle. For bypass installations, refer to the kit instructions for mounting the turbine. Use either reflective material or BVM heat shield paint to protect the fuselage near the hot section of the turbine. **Do not mount electrical components, fuel tubing or parts that could melt around the hot section of the turbine.**

Inlet Protection

Especially for models that have the air intake below the fuselage behind the nose wheel (F16 for example), there is the danger of small stones or dirt entering the turbine. In these cases you must incorporate intake protection (screen) in front of the turbine.

JetCat recommends a “Jet Net” to protect the turbine from debris. Available from **JetCat!**

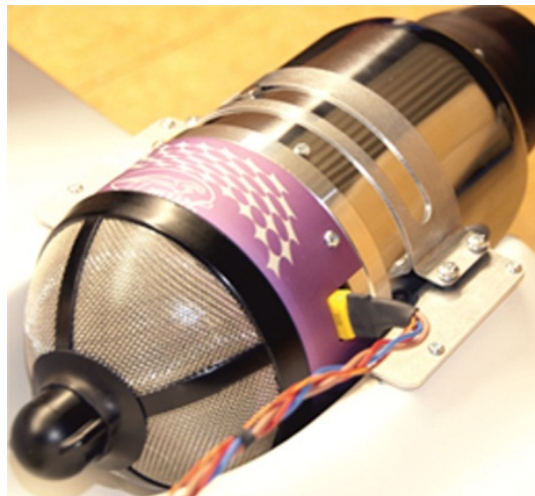

Connections

Once you have unpacked and identified all the components, follow the system diagram/photo for all connections.

Complete System Connection Diagram

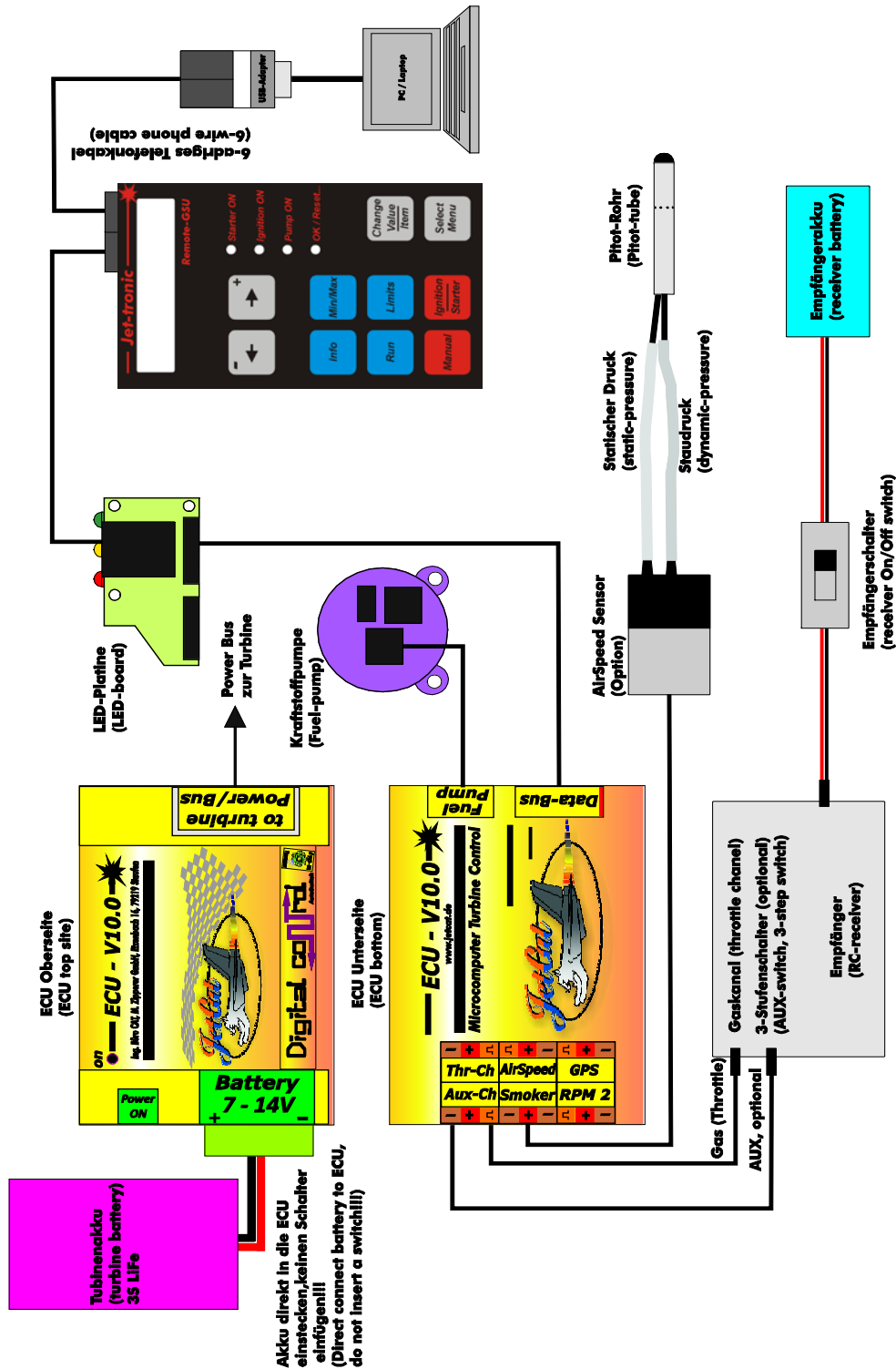

Complete System Connections Photo

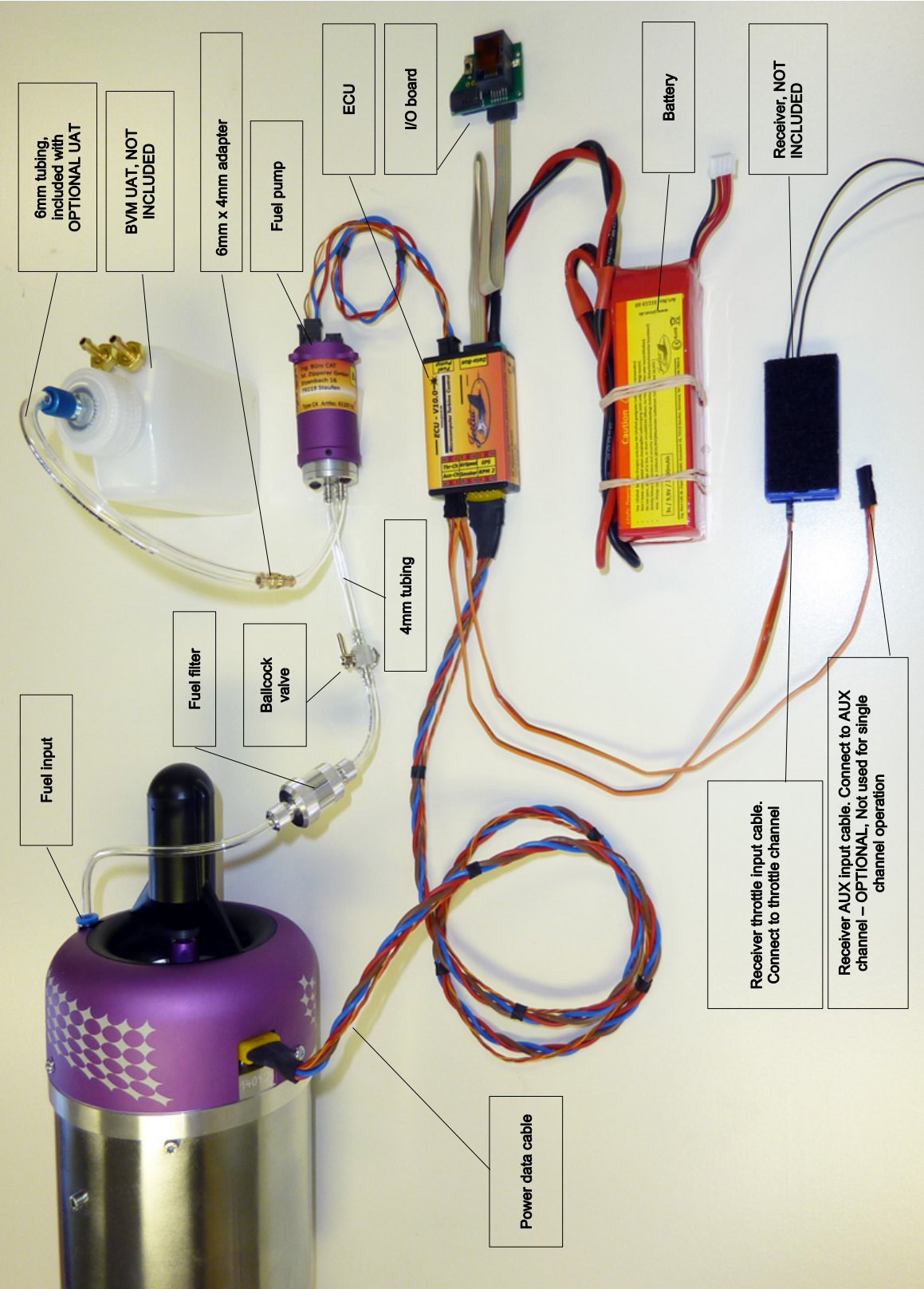

Fuel connections

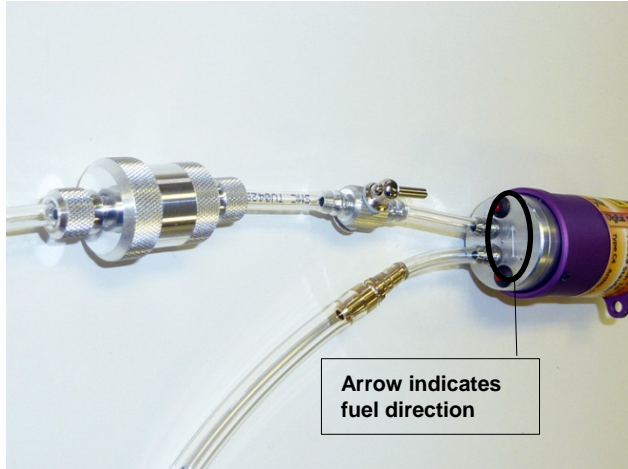



When installing tubing on a metal nipple fitting, secure the tubing by a double loop of safety wire around the connection. To remove tubing from the nipples, you must cut the tubing off. Be careful not to damage the nipple when cutting off the tubing. Warming the tubing can make it easier to slip over the nipple fitting. To insert tubing into Festo quick release fittings, use firm pressure until you feel the tube snap in. To release, press in on the blue plastic front ring, while pulling the tubing out.

The ballcock valve can be put on either side of the filter. When assembling the fuel filter, use caution not to pinch the O-ring when assembling. Clean off aluminum dust and **lubricate fine threads** before assembling.

We recommend mounting the fuel filter vertically. This will limit the possibility of air being trapped inside and then coming out at an inopportune time. It is also better not to affix it but to leave it free to slightly move.

ALWAYS use a gasoline-compatible stopper in your fuel tanks. **Silicon stoppers swell and leak.**

	The fuel demands are high, especially on larger engines, and require large tubing interconnecting the tanks. Use the 6 mm to 4 mm adapter to reduce the UAT 6 mm tubing to the 4 mm tubing connecting to the pump inlet.
---	--

	For safety reasons, JetCat recommends to replace the fuel pump after 25 hours of flight!
---	---



Hopper Tank - UAT

A hopper tank is recommended, between the main fuel tank and the turbine. **JetCat** highly recommends the **BVM** UAT for the hopper tank! The UAT is available as an option from **JetCat**.

Always use the filter between the fuel pump and the turbine as shown in the diagram. This is true even when using the BVM UAT! The pump can emit small particles that can block the internal solenoid valves from completely closing!

Electrical connection

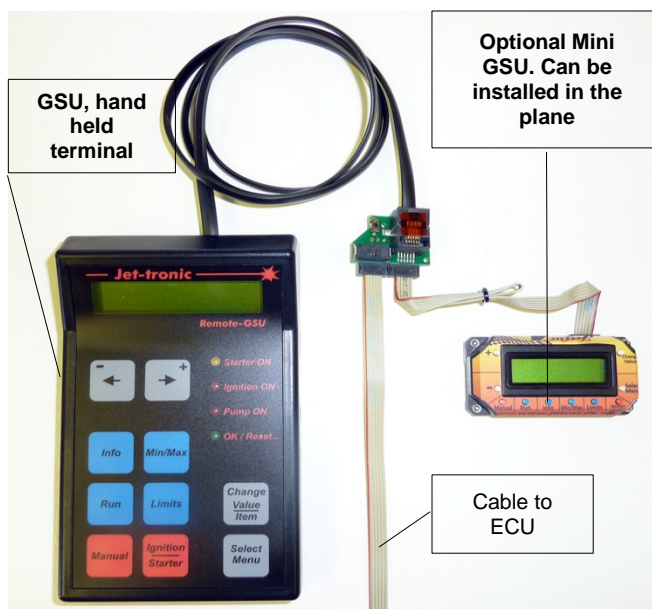
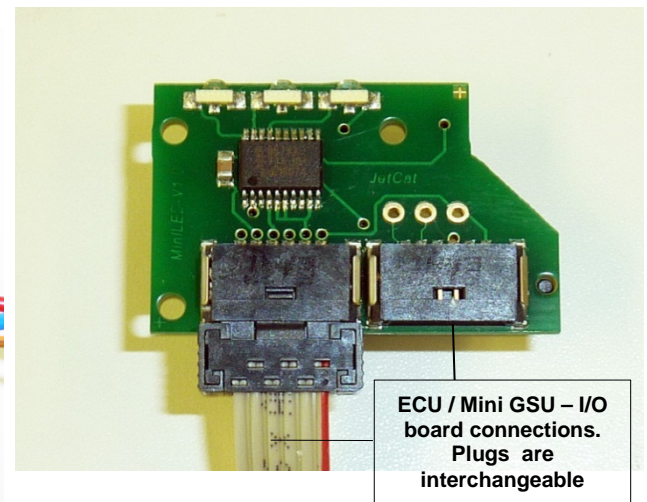
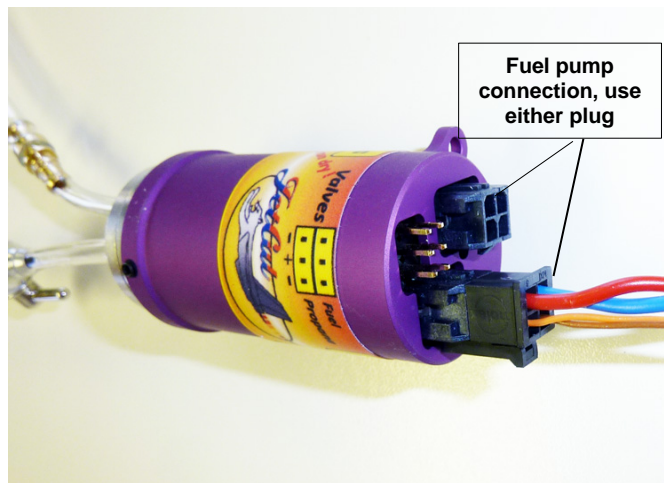
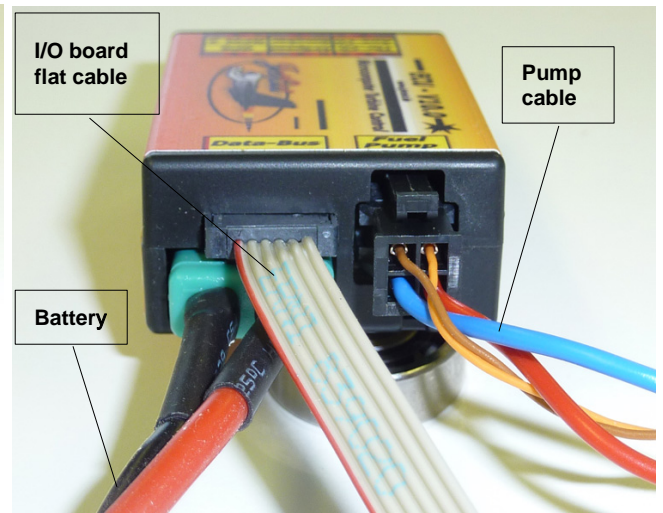
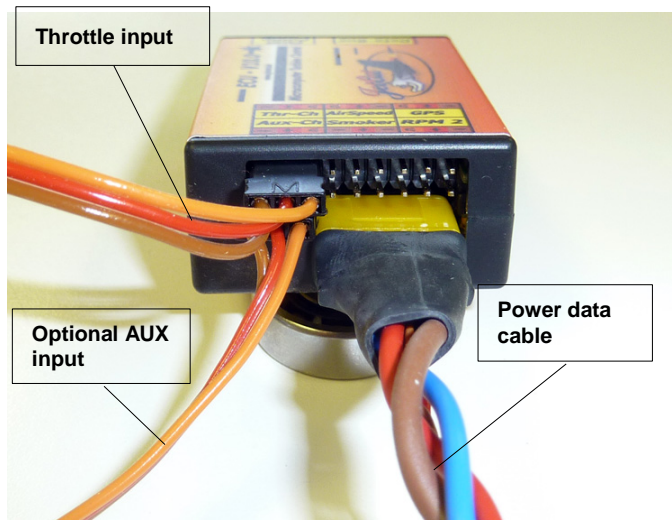



Interconnections

- Connect the fuel pump cable to either connector on the fuel pump and the ECU.
- Connect the Power/Data cable to the turbine and ECU.
- Connect the Flat cable to the LED I/O board and ECU.
- Connect a fully charged battery to the ECU. To charge the battery, refer to the **Power** section of this manual.

Power

The operating power for all components of the turbine (starter / glow plug / ECU / fuel pump / valves ...) is from a **3-cell 9.9V 2200 mAh LiFePo** battery. Alternatively, a 2 cell 25C or better LiPoly battery can be used, refer to battery types later in the manual in the **Limits Menu** options. The battery plugs directly into the ECU and the ECU powers on automatically when the receiver is switched on. If you plan to store the model for more than a few weeks, the battery should be disconnected.

	<p>Attention! Fire! A LiPo/LiFePo battery can explode if incorrect charge parameters are used. You should therefore always refer to the manufacturer's charger instructions. NEVER charge the batteries unattended. Do not exceed the batteries maximum allowed charging current. READ AND OBEY WARNINGS ON BATTERY BEFORE CHARGING!</p>
---	--

	<p>Always ensure the batteries are at their optimal charge state before use. The battery is heavily loaded because of the kerosene start. Please also note that at very low ambient temperatures, LiPo/LiFePo batteries have lower capacities. IMPORTANT: DO NOT INSERT A SWITCH BETWEEN THE BATTERY AND ECU.</p>
---	--

Battery balance adapter

Included is an adapter for the **JetCat** battery balance connector. Use this adapter for most balance enabled chargers sold in the USA.

Example shown with a Thunder Power balance adapter board

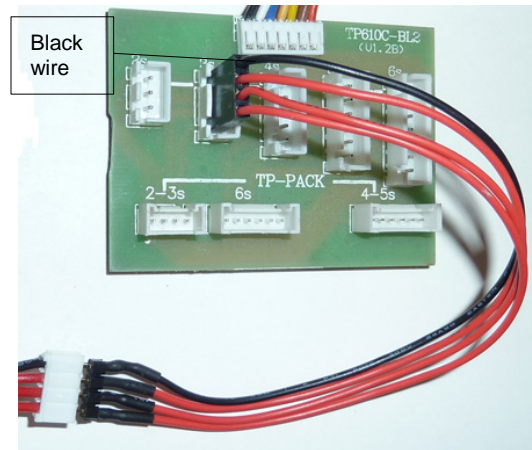

LiFePo balance adapter

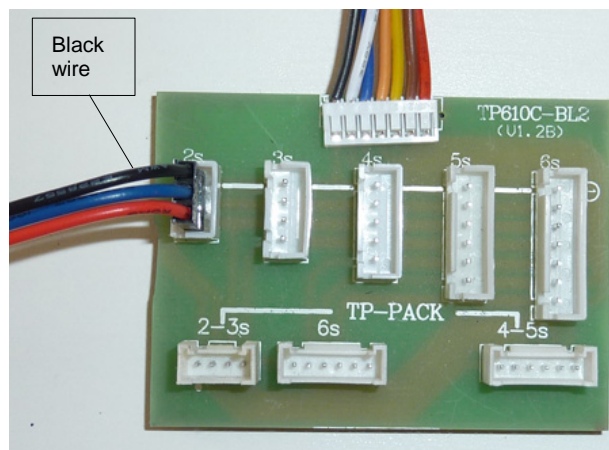

LiPo balance adapter

Fully charge the battery before operation. The battery consumption uses about 300-500 mAh per flight (approx. 10 min., including starting and after run cooling).

Ground Support Unit (GSU)

The GSU serves as a terminal for displaying and programming turbine parameters. It may be connected or disconnected at any time. The real time nature of the ECU allows the operator to adjust the turbine's parameters, even when the turbine is running.



GSU Control Panel Descriptions

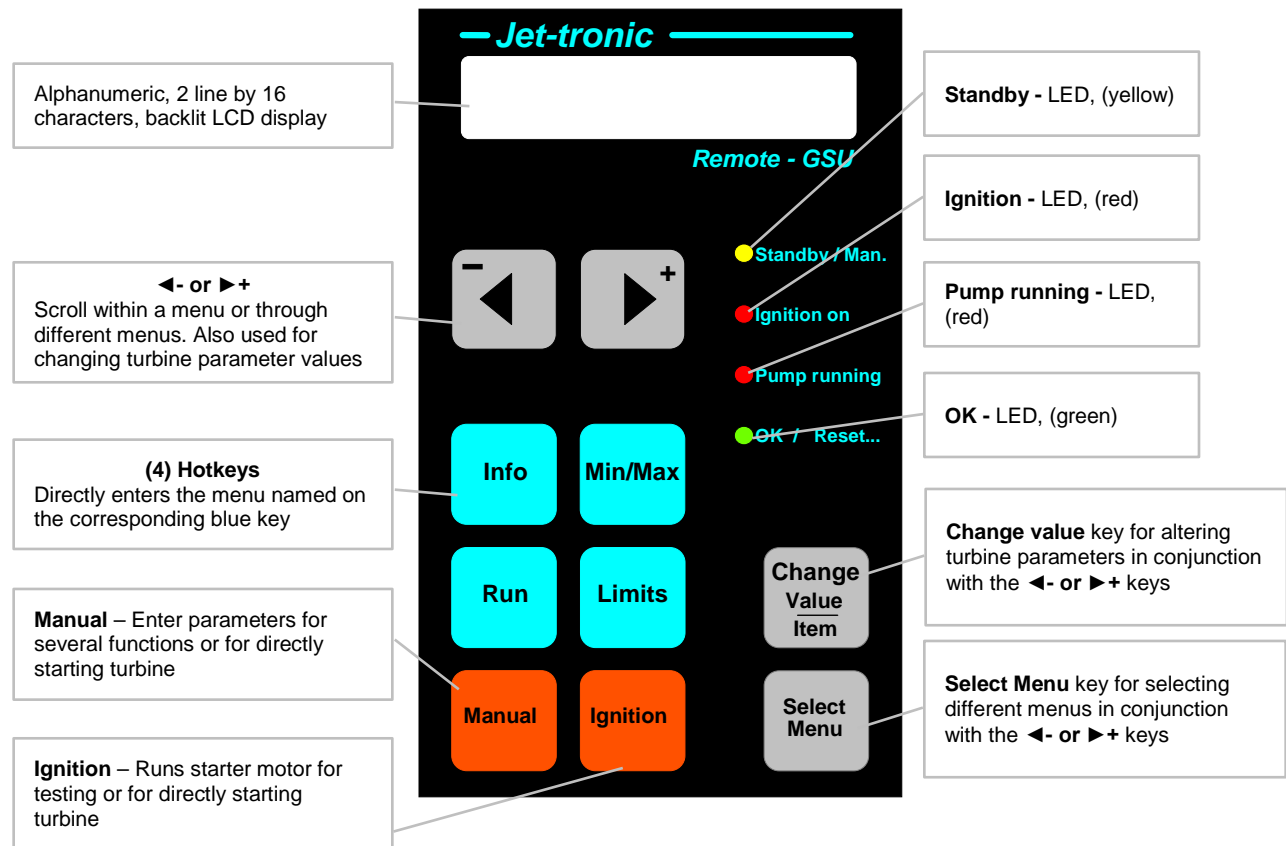

OPTIONAL: Mini GSU, Part# A1027-MINI

With all the functionality of the larger version and, because of its small size and weight, it can be mounted in the model providing direct access to all information and functions.



GSU Switch Descriptions

Key	Explanation
Info	Directly displays the Info menu (Hotkey).
Run	Directly displays the Run menu (Hotkey).
Limits	Directly displays the Limits menu (Hotkey).
Min/Max	Directly displays the Min/Max menu (Hotkey).
Select Menu	When the Select Menu key is pressed and held, the ◀ - / ▶ + keys are used to select another menu. When a desired menu is reached, release the Select Menu key, and your selection becomes the currently displayed menu.
Change Value/Item	When the Change Value/Item key is pressed and held, the ◀ - / ▶ + keys are used to change the indicated value. If the value is admissible to change, a small arrow appears in the display before the value. If the indicated value cannot be changed (e.g.: current RPM or temperature), the display will indicate that the "Value/Item cannot be changed".

	<p>Please take the time to understand the table above especially the descriptions for the Select Menu and Change Value/Item keys. These are often used for viewing additional menus other than the Hotkey menus and for changing ECU settings.</p>
---	--

The LED I/O Board

The LED I/O (Input/Output) board is a connection point for the data bus and a display for the current status of the ECU. The LED I/O board also features a pushbutton switch function to learn your R/C system, calibrate EGT probe or reset all parameters back to default (when powered up). These procedures are described later.

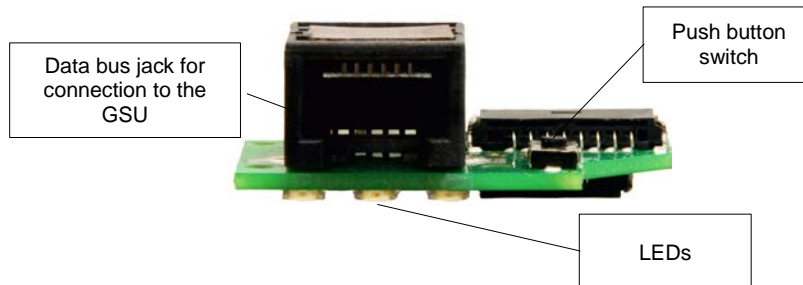

Description of LEDs on the GSU and LED board

Color	Designation	LED is a	LED flashes
Yellow	Standby / start	Starter Motor engaged	---
Red	Pump running	Fuel pump is on	Kerosene glow plug defective or turbine power / data cable is disconnected
Green	OK	Turbine running: throttle control active	If the turbine is running, the EGT is exceeding the maximum temperature. If the turbine is off, Slow Down mode is active

	If the yellow Standby and green OK LED's blink simultaneously, the battery is low and must be recharged.
---	--



OPTION: Part# A1028-CP
 The I/O board is enclosed within a housing and includes a connector for charging the battery.



WARNING!
 When you charge a LiPo/LiFePo battery, the battery must be removed from the plane and never left unattended. **READ AND OBEY WARNINGS ON BATTERY BEFORE CHARGING!**

Jetcat V10 ECU

Switching on the ECU

The battery is directly plugged into the ECU connector or via the optional Charge Plate I/O board (part #A1028-CP). **NEVER use a switch between the battery and ECU!!!**

The ECU turns on automatically when power is applied to one of the two receiver connections, (THR and / or AUX channel). If the ECU was powered on with the transmitter off (no servo pulse), then there is a 60 second delay if the ECU is immediately powered off. To force the ECU to power off, simultaneously press the "Manual" and "Run" switches on the GSU.

The ECU can also be turned on without the receiver being powered on. To do this, there is a switch on the ECU labeled "on" and with a ballpoint pen or similar device, press the switch for 5 seconds. Settings can now be made or the turbine can be started via the GSU. After 60 seconds of inactivity, the ECU will shut off automatically. By simultaneously pressing the "Manual" and "Run" switches on the GSU, the ECU can be turned off immediately.

If the GSU is connected to the ECU then immediately after switching on the ECU, the GSU will briefly display the software version number, starting fuel type and turbine type.



ECU version, V10.1G in this example

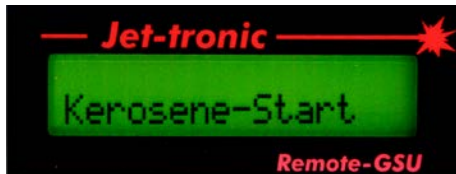

Starting fuel type, kerosene in this example

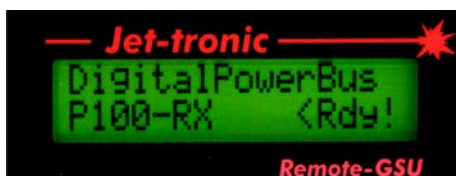

Turbine type, P100-RX in this example

Single or two channel operation?

The turbine may be operated with either one or two channels from your receiver (throttle only or throttle and an auxiliary channel). If single channel is selected, starting, stopping and controlling the power is all accomplished with just the throttle channel. If two channel operation is selected, an auxiliary channel can be used to start, stop or optionally control other special features of the ECU like the smoke pump and airspeed control explained later in the manual. Most commonly, one channel is used.

How to set your ECU for single channel operation

Single channel operation can be selected automatically by not connecting the auxiliary channel cable to the receiver. When you are in the **learn R/C** mode, it will detect the auxiliary channel is not plugged in and will automatically change to single channel operation (auxiliary channel = **Not Used**).

To manually select one or two channel operation, follow the instructions below. This is required for changing from single to two channel operation.

- Plug in the GSU and power up the system.
- Press the **Limits** key.
- Using the **▶+ key**, scroll through the selections until **AUX-channel func** is displayed.
- There are three selections in the **AUX-channel func menu**. While pressing the **Change Value** key, use the **◀ -** or **▶+ key** to scroll through these selections.

:ON Turb Ctrl ON	Aux channel enabled for speed limiter functions and/or Smoker. Turbine control enabled.
:ON Turb Ctrl OFF	Aux channel enabled for speed limiter functions and/or Smoker. Turbine control disabled. You still need to use the AUX channel for speed limiter and/or smoker functions but the turbine control will be in Single Channel Mode.
:Not Used	Single Channel Mode. Totally disable the AUX channel input for turbine control, speed sensor and smoker functions. AUX channel wire does not need to be connected to the receiver in this mode. If Not Used is selected and you have a speed sensor, the Maximum Limit Speed is still active, limiting the maximum speed your plane will fly. You cannot disable this safety function.

Setup failsafe mode

The ECU has the unique ability to shut-off your turbine if you have a radio failure. This is accomplished by detecting that the signal from the receiver's throttle output is either missing or outside the values that were learned during setup.

YOU ARE REQUIRED TO USE THE FAILSAFE!

This will not instantly shut off the turbine. A timer is started when the failsafe condition occurs and the turbine will immediately go to idle. After 2 seconds (AMA requirements as of March 1, 2004) the turbine will then shut off. This 2 second timer is reset back to zero anytime a non-failsafe condition is met. Your R/C signal must be broken for at least 2 continuous seconds before the turbine is shut off.



The following failsafe instructions are for PCM or Spread Spectrum receivers only. (PPM Receivers are not allowed under AMA rules.)

Setting the failsafe

The following procedures are for most radios like JR, Futaba or Airtronics/Sanwa →

If you look at the following servo travel graph below, you can see how the ECU detects a failsafe condition. The gray bar is the transmitters throttle channel end points set for +/- 100% travel. This is the travel range when setting the transmitter's failsafe. The white bar is a reduced end point travel set for +/-

50% travel. This is the value that will be taught into the ECU. If the throttle input to the ECU is between 50% for low throttle, low throttle trim and 50% for high throttle, then this would be within the ECU's taught range and will operate normally. If a failsafe condition exists, the transmitter's pre-programmed 100% low throttle, low throttle trim will be outputted by the receiver and this value would be outside of the ECU's taught in range. The ECU will now automatically set the turbine to idle (after a default 0.1 second **FailSafe delay**) and start a programmable timer. The timer is set to 2 seconds by default. If the timer times out, the ECU will shut-off the turbine. If at any time during this countdown the receivers signal is reacquired, the ECU timer will be reset and the turbine will go back to the speed the throttle stick is currently at.

Setting the travel range to +/- 50% does not affect the RPM range of the turbine.

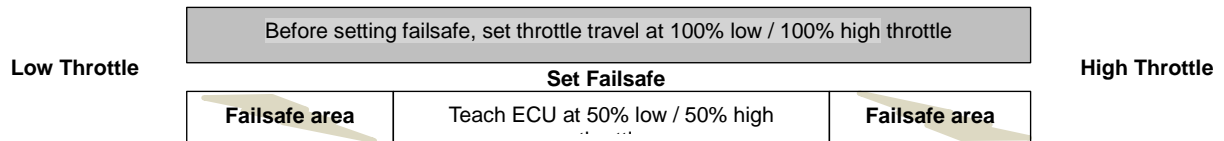

	If you change your transmitter's failsafe after these steps are completed, you must redo the following instructions again.
---	--

FOR TWO CHANNEL OPERATION: Do not enable the auxiliary channel in your transmitter for failsafe. Keep it in **hold mode** only. The auxiliary channel is always designed to stop the turbine instantly if commanded to do so.

For spread spectrum radios, there are two different ways to set the failsafe. It is either accomplished by the transmitter's failsafe menu or by binding the receiver to the transmitter. Refer to your transmitter's manual on how to set the failsafe.

To set the failsafe, you must execute the following steps. It is **VITAL** that these steps be performed in this order for the failsafe feature to operate properly. **YOU MUST PERFORM THESE STEPS!**

- Inspect the transmitter programming to ensure that dual rates and exponential functions are disabled and sub trim is set at zero for both throttle and, if two channel operation, the auxiliary channel. Some transmitters have a travel limit menu in addition to travel end points menu. If so, set the limits to its maximum amount $\geq 100\%$
- Set your transmitters end point travel parameter to +/- 100% for low and high throttle.
- If you are using two channel operation, position the auxiliary channel to the center position.
- Set your transmitters throttle stick to low throttle and low throttle trim. Depending on the radio system you are using, either set the throttle channel for failsafe and store/memorize this minimum position or bind your receiver to the transmitter.
- Return to the travel end point menu and now set the low and high throttle end point to +/- 50%.
- Now you must teach in these values into the ECU. Refer to **Learn R/C** section next in this manual.

Additional Failsafe menus are explained in the manual's advanced section.

“Learn R/C”. Teach the ECU to the R/C System

Before the ECU can be used for the first time you must program the failsafe and learn the throttle stick and optionally the auxiliary control positions of your R/C system.

To accomplish this, complete the following steps:

1. Connect one or both ECU servo cables to the receiver depending on either using single or two channel operation. The **“THR”** cable connects to the throttle channel and if used, the **“AUX”** cable must be connected to a channel capable of three (3) positions or a variable control.



















Make certain that all other connections are made in accordance with the **Electrical Connection Diagram**.

Note: Even if you do not use the auxiliary channel for control, you can still plug the “AUX” cable into an unused receiver channel for a redundant power signal connection. However, if this is done, you must manually disable the auxiliary channel in the limits menu.

2. While pressing the **Select Menu** key on the GSU, switch on the receiver.

Note: Instead of the **Select Menu** key on the GSU, the small button switch on the LED I/O board may be pressed instead. This key can also be used to advance through the **learn R/C** sequence (described below). This feature is useful when the GSU is not available. Keep in mind that the LED's on the I/O board are the same as the GSU for **Standby, Pump running** and **OK**.

Release Select Menu only after the three LED's display the following blink sequence:

LED	Blink Sequence
Standby/Man.	Yellow      
Pump running	Red  ⇒  ⇒  ⇒  ⇒  ⇒ 
OK	Green       ...

The GSU screen will display:

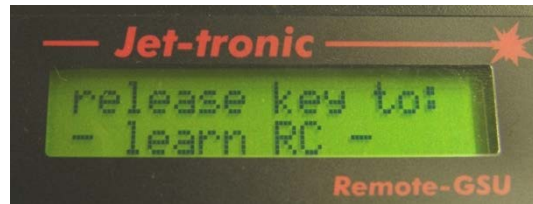

3. This procedure enables a system mode, whereby the stick positions can be learned by the ECU. When **Select Menu** is released, only the green **OK** LED should illuminate. If the pulse width number is “:0 us” and the green **OK** LED is flashing rapidly, then there is a problem with the receiver output. Test with a servo and ensure the transmitter / receiver are working correctly. To test the connection, move the throttle stick and the pulse width number should change. If not, the **THR** cable is not connected to the correct channel.

The GSU screen will display:
→ Throttle channel “Off” position



4. Now the ECU can memorize the positions of the throttle and AUX channels. First, place the throttle stick and throttle trim to minimum. Next, press **Select Menu** or the LED I/O board button switch again. This will store the R/C system's pulse width for immediate shutdown of the turbine. The green **OK** LED will turn off and the red **Pump running** LED will illuminate.

The GSU screen will display:
→ Throttle channel “Idle” position

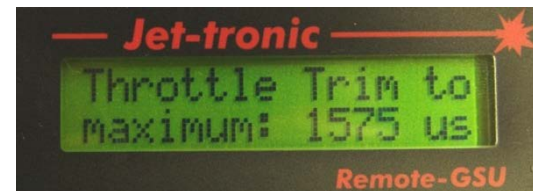

5. Advance the throttle trim lever to maximum. Press **Select Menu** or the LED I/O board button switch again to store the R/C system's



pulse width for the turbine idle position. The red **Pump running** LED will turn off and the yellow **Standby** LED will illuminate.

The GSU screen will display:
→ Throttle channel "**Full Power**" position

6. Advance the throttle stick to maximum. Press **Select Menu** or the LED I/O board button switch again to store the R/C system's pulse width for the turbine full power position. The yellow **Standby** LED will turn off. If your ECU is set up for single channel operation skip to instruction number 11.

The GSU screen will display:
→ AUX channel minimum "**Off**" position.



7. If the ECU is set for two channel operation, continue to program the auxiliary channel. The green **OK** LED will illuminate again and initiates the learn mode for the three-position auxiliary channel.
8. Move the auxiliary channel to the minimum position for **Off** and press **Select Menu** or the LED I/O board button switch again to store the R/C system's pulse width for immediate shutdown of the turbine. The green **OK** LED will turn off and the red **Pump running** LED will illuminate.

The GSU screen will display:
→ AUX channel center "**Start/Standby**" position

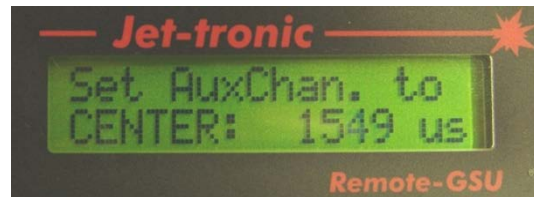

9. Set the auxiliary channel to the middle position for **Start/Standby** and press **Select Menu** or the LED I/O board button switch again to store the R/C system's pulse width for the turbine to start and run. The red **Pump running** LED will turn off and the yellow **Standby** LED will illuminate.

The GSU screen will display:
→ AUX channel maximum "**Auto-Off**" position



10. Set the auxiliary channel to the maximum position for **Auto-Off** and press **Select Menu** or the LED I/O board button switch again to store the R/C system's pulse width for a normal auto shut-off of the engine. The yellow **Standby** LED will turn off.
11. The green **OK** LED will flash and the display will briefly show "SAVING SETUP DAT" and then return to the normal default **RUN** screen. Return the throttle stick and trim to the minimum position and the auxiliary channel (if used) to **Off** and the green **OK** LED will turn off. This completes the programming. The ECU will now permanently store the data. Repeating this procedure is only necessary when the R/C system is changed or adjusted.

Note: This data is permanently stored in the turbine. If you change ECUs, the turbine data will be copied into the new ECU and the “learn R/C” will not need to be redone.

Verify failsafe programming

You can verify the failsafe function in the default **RUN** screen with the GSU. With your receiver and ECU on, turn off the transmitter. After about two seconds a F_L should display on the screen.

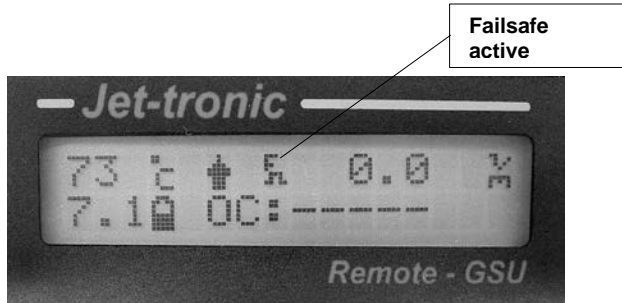

Turn your transmitter back on and the F_L should clear from the screen. **The failsafe must function to operate the turbine in a safe manner.**

Preparing fuel and fuel system

	<p>Warning! Obey local laws for the transportation and storage of fuels.</p> <p>Fire warning! When mixing the fuel with oil or when operating (fueling, defueling, etc.), never handle near an open flame. Please do not spill or empty fuel to the ground.</p>
--	---

The **JetCat** engine can use deodorized kerosene, 1-K kerosene or Jet-A1 for fuel. Fuel must be mixed with 5% synthetic turbine oil.

Example formula: 1 quart of oil in 5 gallons of fuel.

JetCat recommends low toxicity **JetCat** oil with anti-static additive or Aeroshell 500 turbine oil although any turbine oil that conforms to MS23699 standards will work.

To reduce static charges from the fuel system, we recommend adding our anti-static additive (Part# A3000) or **JetCat** Turbine Oil (Part# A3001) with anti-static additive already blended in.

	<p>Please note: Fully synthetic 2-stroke oils or Mobil DTE are not suitable and should not be used.</p>
--	---

Fueling on board tanks

	<p>Before filling the on board tanks, as an added safety, shut off the manual ballcock valve. This will prevent fuel from entering the engine in an unlikely case the solenoid valves leak. Do not fill the on board tanks too quickly. There is capillary resistance in a series tank system, possibly causing a high pressure rupturing of a tank.</p>
--	--

Fill the on board tanks through the **UAT** tank filling tube. Make sure the “fuel dot” is fitted after refueling. It is important to check the “fuel dot” for a secure fit. If it leaks, the UAT can fill with air, causing the turbine to shut down.

Prime the pump and system

To prime the fuel pump and fuel lines (or for fuel pump test purposes), it is necessary to open the fuel solenoid shutoff valve and run the fuel pump manually. For this purpose, use the **Test-Functions Menu** selection, **Fuel Pump Test (Purge Fuel)**. This test opens the fuel valve and acts as a speed control for running the pump. **Note:** RX engines have internal solenoids so the valve function is irrelevant.

	<p><u>Before activating the purge pump mode, ALWAYS remove the fuel feed line connected to the turbine.</u></p> <p>Pump Test / Purge Fuel allows the fuel pump to operate without the turbine running. However, if the fuel feed line is not removed from the turbine during this procedure; it will become flooded with fuel. When this occurs, the next turbine start can become highly combustible!</p>
---	---

Use the select menu key and select the **Test-Functions** menu.

	<p>Remember when the Select Menu key is pressed and held, the ◀ - / ▶ + keys are used to select another menu. When a desired menu is reached, release the Select Menu key, and your selection becomes the currently displayed menu.</p>
---	--

Press the Change Value/Item key to run the pump. If you want to change the voltage the pump runs at, press either the ◀ - or ▶ + while pressing the Change Value/Item key. It is best to lower the pump voltage back down to the 0.5V default amount when finished.

Running the turbine for the first time

The Checklist

Before Running the Turbine

- Charge ECU Battery. **You must read and obey warnings on the LiPo/LiFePo battery pack.**
- Prepare CO2 fire extinguisher
- Check fuel lines and filter. Make sure they are clean with no restrictions
- Check that the fuel tank vent is unobstructed
- Mix 5 % oil in fuel (i.e.: 1 quart per 5 gallons of kerosene)
- Fill fuel tank(s). Make sure the main and header tanks are full
- Turn on receiver switch
- Place the model with nose into the wind
- Activate brakes and start turbine

After Stopping the Turbine

- Turn model into the wind. Activate brakes and stop turbine
- During the cooling process the receiver switch can be shut off at any time. When the cooling process is complete, the ECU will automatically shut off
- After each flying session, defuel the tanks before storing.

	<p>WARNING!</p> <p>In case of a mishap, fire extinguishers should be on hand at all times. <i>JetCat</i> recommends the CO/2 variety. Powdered extinguishers will corrode the precision components inside the turbine and void your warranty.</p>
---	--

Starting and stopping the turbine

1. Prepare to start by completing the startup checklist.
2. Single Channel Mode start/stop procedure.

- a. To start the turbine, place the throttle stick and trim to their minimum positions. Next, move the trim to its maximum position. Finally, move the throttle stick to its maximum position.
 - b. When the throttle stick is set to the maximum position, the ECU will begin a fully automatic starting sequence. This starting sequence can be immediately stopped at any time by moving the throttle stick and trim to the minimum positions.
 - c. To stop the turbine after it is running, throttle up just above idle and let it stabilize for a couple of seconds, then move the throttle stick and throttle trim to their minimum positions. The auto-cool down mode will start when the turbine has nearly stopped rotating.
3. Two Channel Mode start/stop procedure.
- a. Set the throttle stick and trim to their minimum positions and the AUX switch to the **Off** position.
 - b. Move the throttle trim lever to its maximum position.
 - c. Set the AUX switch to the middle **Start/Standby** position. The turbine is now ready to start!
 - d. Advance the throttle stick to its maximum position and the turbine will start.
 - e. Once the turbine begins to accelerate, the throttle stick can be returned to idle position.
 - f. When the throttle stick is set to the maximum position, the ECU will begin a fully automatic starting sequence. This starting sequence can be immediately stopped at any time by moving the AUX switch to the **Off** position and/or reducing the throttle stick and trim to the minimum positions
 - g. To stop the turbine after it is running, set the AUX switch to the **Auto-Off** position. The turbine will increase RPM above idle, stabilize and then shut off. The auto-cool down mode will start when the turbine has nearly stopped rotating.
4. As soon as the turbine stabilizes at idle speed, the green **OK** LED will illuminate, indicating that thrust control is now handed over to the pilot. The throttle stick must be in the idle position for the green **OK** LED to illuminate.

	<p>When initiating a start, the LED's will blink in a continuous sequence of green to red to yellow. If the throttle stick is above minimum position when initiating a start sequence, the LED's will blink in a continuous sequence yellow to red to green indicating an error. Bring the trim to the maximum position and the throttle stick to the minimum position and this will correct the error condition.</p>
---	---

After the start process is initiated, the following occurs:

1. After the start signal has been received, the starter motor is shortly activated to give an "acoustical signal" that the start sequence has been initiated.
2. Now the Kerosene-Igniter is pre-heated for approximately 5 seconds (the starter motor is not running).
3. Next, the starter motor spools up the turbine to a constant speed and then starting fuel pulses into the turbine until the combustion chamber rises above 120 degrees C. The yellow **Standby** LED will illuminate when the starting motor engages. Should ignition not occur, after a 30-second period of time, the process is aborted and the green **OK** LED will blink.
4. Turbine RPM will progressively increase until achieving stable speed. When the turbine speed surpasses the idle RPM value, the starter motor disengages and the yellow **Standby** LED goes out.
5. As the turbine approaches its stabilize RPM, it will briefly dwell, before automatically decelerating to idle RPM.
6. When the turbine attains idle speed and the throttle stick is placed at idle position, the green **OK** LED will illuminate, indicating that thrust control is now handed over to the pilot.

Automatic Cooling Process

After the turbine spins down from **Auto Off** or **Manual Off**, the starter motor will spin the turbine rotor at a slow constant speed until the **Exhaust Gas Temperature** is below 100° C.

	<p>ATTENTION! <u>Two channel control only:</u> In unsafe situations (e.g.: a model fire), the automatic cooling process may contribute additional oxygen. To immediately discontinue the cooling process, bring the throttle stick to idle, throttle trim to the minimum position and the AUX switch to Off.</p>
--	--

GSU (Run menu default) display symbols

Initial default display screen after power up

Exhaust temperature in °C

Battery voltage

Battery icon shown ½ full

Off Condition – none indicated

Turbine RPM In 1000 units

After power up – “error condition” display screen

Igniting plug defective

Failsafe active, transmitter off?

Flashing -E-, EGT sensor defective

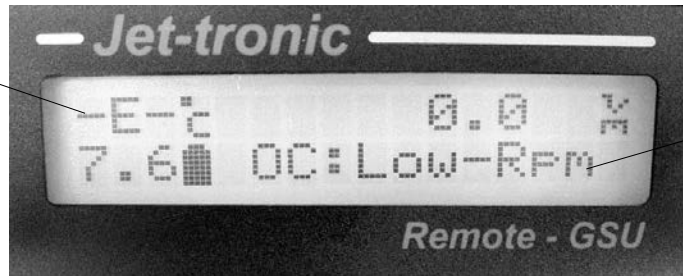

Last Off Condition, Low RPM shut-off from previous run

Turbine starting display screen

Exhaust temperature in °C.

Current pump voltage

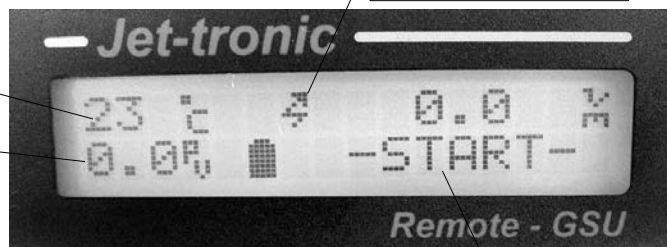

Started directly from GSU – explained in advanced section

Current state, only during startup

Turbine running display screen

Actual RPM in thousands

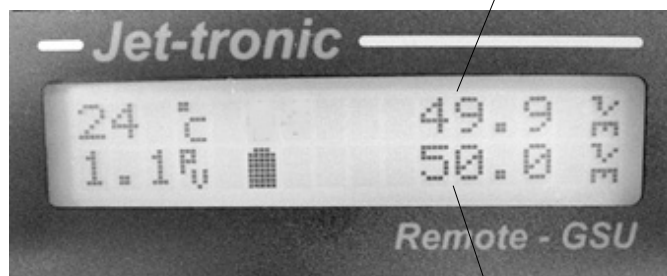

Set RPM, commanded from transmitter

Turbine Running States

The **JetCat turbine** progresses through several operating states, from ignition to the cool down process. The transitions of these states are automatically controlled by the ECU and by user commands. The current value is always displayed on the GSU screen in the **STATE** selection in the **RUN** menu. When the turbine is starting, the GSU will also display the current state on the bottom line of the display. Whenever the engine is in cooling mode or the starter is tested with the **Ignition** key, the top line of the GSU display will flash “! – Cooling - !”.

Explanation of the Turbine States

Table 1

Value	Explanation
-OFF-	AUX switch in the Off position and/or the throttle trim in the Off position. All LEDs are off. Turbine is off (preventing starting).
Standby / START	AUX switch positioned to the Start / Standby position, throttle trim at maximum and throttle stick at idle. The LED chase sequence is started from green to red to yellow, continuously. When throttle stick is advanced to the maximum position, the starter motor engages to spin the rotor. When RPM reaches a pre-programmed value, the starter motor's voltage is removed and the turbine is ready to ignite .
Pre Heat 1	The burner is pre-heated for 3-7 seconds (the starter motor is not running)
Pre Heat 2	The starter motor spools up the engine to it's ignition. After another few seconds the ignition of the engine is engaged by injecting kerosene into the Kerosene-Igniter. The pump and the internal starting fuel solenoid will begin pulsing.
MainF-On	Main fuel solenoid opens and kerosene is modulated into the engine.
AccelDly	Delay while combustion chamber is preheating. Waiting for a rise in EGT.
Ker.Full	Starting fuel solenoid closes and all the fuel is now directed to the main injectors. The red Pump running LED turns on and will stay illuminated as long as the pump operates.
Stabil.	Turbine successfully accelerates to the idle RPM, then automatically increases speed to about 30% higher RPM. When this speed is maintained consistently for at least one second, the turbine will proceed to the next state (Learn LO).
Learn LO	In this state, the turbine automatically decreases RPM to the idle speed. As soon as idle speed is attained, with the throttle stick in the idle position, the turbine will proceed to the next state (RUN (reg.)).
Run (reg.)	Turbine in the normal running state; the throttle stick will regulate turbine thrust. During this operant condition, the green OK LED will illuminate, indicating that pilot has control. (red LED is already illuminated) RUN (regulated) continues, until the turbine is switched off.
Auto Off	The AUX switch placed in the Auto Off position. Turbine automatically increases RPM if at idle and remains at that RPM for a few seconds, before transition to the next state (Slow Down).
Slow Down	During this state, the fuel shut-off valve is closed and the fuel pump is stopped. The green OK LED blinks and the GSU displays !-Cooling-! , indicating Slow Down This condition will continue, until all of the following parameters are met: <ul style="list-style-type: none"> • Turbine speed less than 800 RPM • EGT is less that 100 degrees C. • The AUX switch is moved to the Off position and throttle trim is moved to the minimum position Once these conditions are met, turbine proceeds to Off .
Speed Control	Speed Control mode -- only active when the air speed sensor is connected. Regulates model flight speed.

Table 2

Code	Value	Explanation
1	R/C Off	AUX switched to Off position or throttle stick and throttle trim moved to the minimum position.
2	OverTemp	Turbine running over temperature. Exceeded high temperature parameter and time out.
3	IgnTimOut	Turbine did not ignite within programmed time interval.
4	AccTimOut	Turbine achieved ignition, but did not accelerate within programmed time interval.
5	Acc.Slow	Turbine achieved ignition, but acceleration was less than the programmed value, during startup.
6	Over-RPM	Turbine exceeded the maximum RPM, by 5% and a delay of 0.5 seconds.
7	Low-RPM	Turbine running under the minimum RPM, by 10% and a delay of 3 seconds. Usually triggered by a flame out.
8	BattryLow	Battery pack is dead. Cell voltage is < 1.0V.
9	Auto-Off	Turbine shut down via the AutoOff sequence, using the AUX channel.
10	LowTemp	EGT dropped below the minimum value. A dislodged EGT sensor can trigger this shut down.
11	HiTempOff	EGT exceeded the maximum range (~950 °C).
12	GlowPlug!	Defective kero/glow plug.
13	WatchDog	ECU processor was locked out usually from static discharge or voltage spike in power supply.
14	FailSafe	Turbine was shut down from a failsafe timeout condition.
15	ManualOff	Turbine was shut off by using the GSU.
16	PowerFail	The power failed to the ECU when the turbine was running. This will occur if the power was lost because of a defective battery, connection or if the switch is turned off before the engine is shut-down. Note: If this state is displayed the Info, Min/Max and Statistics menus retain information from the previous run.
17	TempSensor Fail	EGT sensor failed. Note: This could happen only during startup.
18	Wrong Pmp	Wrong pump type, see pump configuration in the advanced section of the manual.
19	No Pump	There is either no pump connected or the pump cable is defective.
20	Over Curr	The electrical current to the engine is too high. <ul style="list-style-type: none"> • Starter may be jammed • Kero/glow plug is short circuited

Troubleshooting

Most frequent errors. Cause and remedy:

Problem	Cause	Remedy
Turbine doesn't ignite	<p>Fuel supply lines are empty or not purged</p> <p>ECU battery weak or empty</p> <p>The kero start igniter failed. The automatic glow plug test may not detect a failed igniter!</p>	<p>Purge fuel system. Use the Test Functions Menu, Purge Pump</p> <p>Charge ECU battery</p> <p>This is an extremely rare event but the turbine must be returned to JetCat. It may be possible on some engine types to use a temporary external plug. Call JetCat for information.</p>
Starting process fails	<p>Turbine is still too warm; Cool Down not yet completed.</p> <p>Low battery or faulty connection.</p> <p>Glow plug defective (red Pump running LED blinks).</p> <p>Three-conductor cable for starter motor and glow plug disconnected.</p>	<p>Wait until SlowDown sequence is finished. The green OK LED will stop blinking.</p> <p>Charge battery. Check ECU's battery connection.</p> <p>Replace defective glow plug.</p> <p>Check cable. Check for proper connection from ECU to the turbine.</p>
ECU doesn't follow full commands from the throttle stick	<p>Programming alteration in R/C transmitter</p>	<p>Check alignment with RC-Check menu. Re-align ECU to the R/C system.</p>
Turbine ignites, but the start process is discontinued.	<p>Air in fuel feed lines.</p> <p>Fuel pump not running.</p>	<p>Air leaks in fuel system. Examine all Festo fittings, nipples, clunk, filter, etc. Check for fuel filter clogs.</p> <p>Test the pump in Test Functions menu, (as soon as the red Pump running LED illuminates, the fuel pump must run!).</p>
Starter unit slips, makes noise.	<p>Dust and oil sediment on the compressor nut and O-ring.</p>	<p>Clean O-ring and compressor nut periodically, with cotton swab and solvent.</p>
EGT giving erratic temperature or RPM readings.	<p>Transmitter antenna too close to the model.</p>	<p>Keep the antenna away from the model. It may cause false readings.</p>
Turbine quits with Watchdog Failure	<p>Static discharge reset the ECU.</p>	<p>Do not mount ECU directly to the fiberglass body of the plane. Use a plywood mount with a layer of foam tape and Velcro between the body and the ECU. If the plane has a glossy finish and the failure happened directly after the wheels left the ground, spray the tires with an anti-static spray available from electronic or hardware supply stores.</p>

Reason for an unexpected Shut-Down

There are three ways to diagnose why the engine flamed out.

1. In the info menu the "LAST OFF-COND" variable will tell you why. For example, low RPM, high temp, fail-safe etc. **This parameter is non-volatile and will be available until the engine is run again.**
2. You can view the last 8 seconds of the flight before it shut-down. This data is updated every 0.2 seconds. This allows you to see the trend leading up to the shut-down. This mode is entered by pressing the "+" key of the GSU while powering up the ECU. You can scroll through the data using the (+ or -) keys and scroll forward and backward through time using the (info or min/max) keys. **This parameter is non-volatile and will be available until the engine is run again.**
3. You can download and view the entire flight using the optional serial adapter Part# A1028-USB and a PC.

If the off condition is "POWER-FAIL" then the data is not valid. This occurs if the ECU or receiver battery was disconnected or was intermittent or if the receiver power goes lower than 3 volts. In this case, the data in the system would be for the previous run.

Sample of displayed values

Tim:	R:	S:	EGT:	Pmp:	Sta:	Th:	Au:	Bat:	AirS:	SetS:
Time	RPM	Set-RPM	Temp	Pump V	State	Thr. pulse	Aux. pulse	Batt volts	Air Speed	Set Air speed
-4.0	0	0	0	0.0	0	0	0	0	0	0

See the **Explanation for Turbine Shut Down** for a description of each state code.

How to diagnose a shut-down from the saved data

Symptom	Engine shut-off state	Possible Reason
Engine quits with a trail of white smoke.	Low RPM or Fuel Fail	This is normally caused by air in the fuel system. Make sure there is no leaks in the fuel system and most importantly, get all the air out of the fuel filter. The fuel filter should not be hard fixed to the plane but allowed to hang free. It is best mounted vertically. When you purge the fuel system, tap the filters while the pump is running to get all the air out them. USE A BVM Ultimate Air Trap!

	If the engine fails to ignite, you CAN get excess kerosene in the engine. YOU CANNOT REMOVE EXCESS KEROSENE BY TILTING THE PLANE WITH THE NOSE UP IN THE AIR. The kerosene will be captured by the exhaust guide vanes and will not run out of the engine. The nose must be tilted down towards the ground. The excess kerosene will then run out the intake. You may need a towel around the intake to absorb the kerosene. Clean off the starter o-ring afterwards since it may get kerosene on it as well.
---	---

Manual advanced section

JetCat ECU features Version 10.00

- Powerful 16/32-bit latest generation microcontroller with substantial program and data memory.
- The ECU can be turned on without powering up the receiver to read data or make adjustments.
- When the turbine is stopped the ECU enters a cooling process. During that time, the receiver can be immediately powered off. The ECU remains on monitoring the cooling process and will switch itself off after it is complete.
- The starter motor is run at a constant speed during the turbine cooling process. This reduces the wear of the starter coupling.
- The settings for the startup pump voltage are eliminated.
- The fuel pump type is automatically detected and displayed.
- Integrated R/C system fail-safe analysis and display of the number and duration of any faults. After landing, the R/C system communication quality can be assessed.
- Programmable fail-safe behavior. The hold times and failsafe reaction time can be programmed.
- RS232 interface for PC connectivity
- Turbine control using either one or two transmitter channels
- Direct start and control of the turbine from the GSU terminal without the R/C transmitter.
- Support for parallel connected turbines (multi engine models)
- With an optional smoke system, the ECU can be programmed to generate warnings for low battery voltage, low fuel or Fail Safe.
- Built-in data logger functions. The data for the last 17 minutes of operation will be stored at a resolution of one sample per second and can be read by the optional PC software. The data remains stored even after a power failure. In addition, the last 8 seconds of operation before shutdown of the turbine is stored with a resolution of 0.2 seconds. This allows for accurate fault diagnosis.
- Input for an optional airspeed sensor for measurement, control and limiting of the model's airspeed.
- Global Position System (GPS) interface for the optional **JetCat** GPS receiver. A highly accurate measurement and display of maximum ground speed, route distance, maximum altitude, maximum flight radius and maximum G-force of the model, etc.
- Advanced test and diagnostic functions for pump, valves and sensors.
- Significantly expanded Information and Min / Max menus.
- Tolerant error detection for the turbine sensors. If a sensor fails the turbine does not immediately shut off but activates an emergency operation mode that may enable a safe landing. After landing, a restart is only possible after troubleshooting the error.

