

*Jline*



# QUATTRO

4-CHANNEL FM RADIO SYSTEM

INSTRUCTION MANUAL  
MANUFACTURED BY JR REMOTE CONTROL

# 1. INTRODUCTION TO THE J-LINE QUATTRO RADIO SYSTEM

Thank you for purchasing the J-line Quattro 4-Channel FM Radio System. This unit has been designed to provide the modeler with a high quality, user-friendly radio system that can be depended upon for years to come.

It is important that you carefully read this manual before attempting to operate your Quattro System. Please pay particular attention to Section 8, Charging Your Quattro Radio System Prior to Installing.

## TABLE OF CONTENTS

<b>1. Introduction to the Quattro Radio System</b> . . . . 1	<b>9. Pre-Installation System Preparation</b>
<b>2. System Specifications</b> . . . . . 2	9.1 Flight Pack Connections . . . . . 7
<b>3. Quattro Transmitter</b>	9.2 Transmitter Preparation . . . . . 7
3.1 Transmitter Features . . . . . 2	9.3 577 Servo Preparation . . . . . 8
3.2 Transmitter Layout . . . . . 2-3	9.4 System Check . . . . . 8
3.3 Transmitter Specifications . . . . . 3	<b>10. Flight Pack Installation</b>
3.4 Control Stick Length Adjustment . . . . . 3	10.1 Installation Suggestions . . . . . 9
3.5 Neck Strap Attachment . . . . . 3	10.2 Servo Reversing . . . . . 10
<b>4. NER-600 Receiver</b>	10.3 Setting Reversing Switches . . . . . 10
4.1 Receiver Features . . . . . 4	10.4 Adjusting Control Surface Travel . . . . . 11
4.2 Receiver Layout . . . . . 4	<b>11. Pre-Flight Information</b>
4.3 Receiver Specifications . . . . . 4	11.1 Quattro Trainer System . . . . . 12
<b>5. 577 Servo</b>	11.2 Operating the Trainer System . . . . . 12
5.1 Servo Features . . . . . 5	11.3 Range Testing Your Model . . . . . 12
5.2 Servo Layout . . . . . 5	<b>12. General Notes</b> . . . . . 13
5.3 577 Servo Specifications . . . . . 5	<b>13. Daily Flight Checks</b> . . . . . 13
<b>6. Airborne (Receiver) Battery Pack</b> . . . . . 5	<b>14. Warranty and Service Information</b>
<b>7. Charger Specifications</b> . . . . . 6	14.1 Warranty Coverage . . . . . 14
<b>8. Charging Your Quattro Radio System Prior to Installation</b>	14.2 Repair Service Instructions . . . . . 14
8.1 Battery Charger . . . . . 6	<b>15. Frequency Chart</b> . . . . . 15

## 2. SYSTEM SPECIFICATIONS

<b>System Name</b>	Quattro	<b>Servos</b>	NES-577 x 4
<b>Transmitter Body</b>	NET-E104	<b>Accessories</b>	Mini Switch
<b>Receiver</b>	NER-600		Servo Accessories
<b>Charger</b>	NEC-221		12" Aileron Extension
<b>Airborne Battery</b>	4.8V 600mAh NiCad		Instruction Manual

## 3. QUATTRO TRANSMITTER

### 3.1 TRANSMITTER FEATURES

- Computer-designed, ergonomically styled case
- Servo reversing on all 4 channels (page 12)
- Adjustable control stick length (page 5)
- Trainer system feature compatible with all current JR radio systems
- Easy-to-read transmitter LED battery voltage indicator
- 9.6V 600mAh NiCad transmitter battery pack
- Power output approximately 750mw

### 3.2 TRANSMITTER LAYOUT

Transmitter LED Battery  
Voltage Indicator

Neck Strap Attachment  
(JRPA023 Optional JR Neck Strap)

Trainer Button

Throttle Trim

Throttle/Rudder Stick

Rudder Trim

Transmitter Antenna

Carrying Bar

Elevator Trim

Elevator/Aileron Stick

Power Switch

Aileron Trim

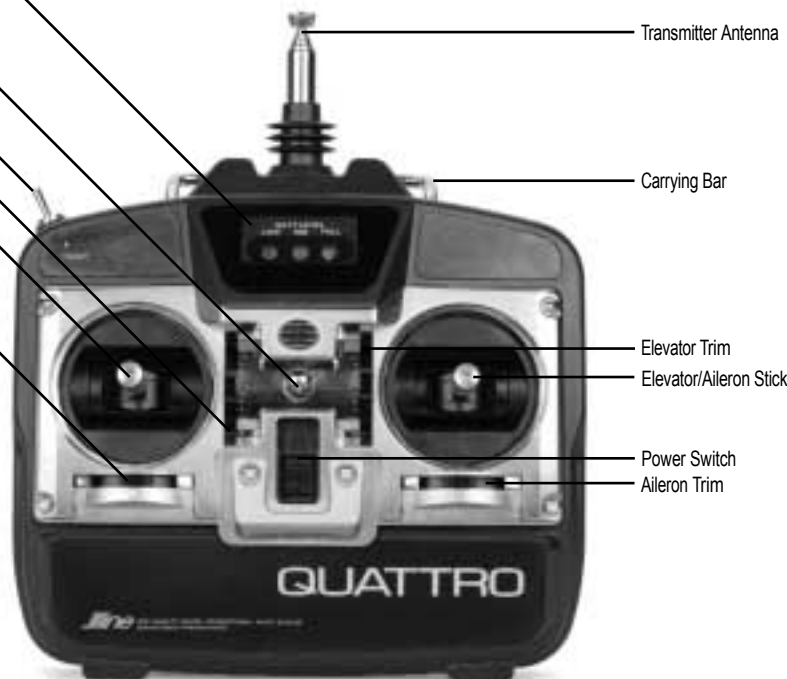
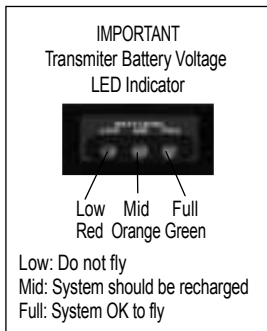

## 3.2 TRANSMITTER LAYOUT

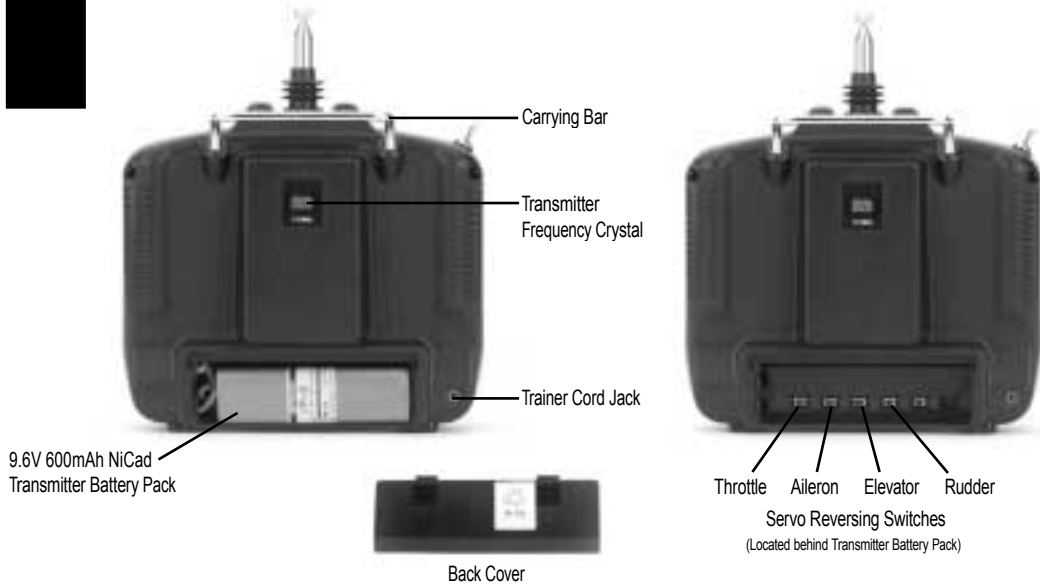

## 3.3 TRANSMITTER SPECIFICATIONS

<b>Model Number</b>	NET-E104	<b>Output Power</b>	Approximately 750mw
<b>RF</b>	72MHz	<b>Current Drain</b>	150mAh
<b>Modulation</b>	PPM (FM)	<b>Power Source</b>	1.2V x 8 NiCad (9.6V 600mAh)
		<b>Output Pulse</b>	1.0 –2.0ms

## 3.4 CONTROL STICK LENGTH ADJUSTMENT

To adjust the control stick length, use a 2mm Allen wrench to unlock the set screw located inside the end of the control stick. Turn the set screw counterclockwise to loosen it, then turn the knurled portion of the stick to adjust the length. Counterclockwise will lengthen the stick and clockwise will shorten it. After the control stick(s) has been adjusted to suit your flying style, tighten the set screw.

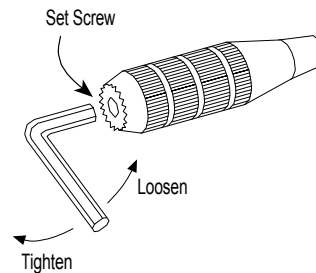

## 3.5 NECK STRAP ATTACHMENT

There is an eye hook on the front of the transmitter for attaching an optional neck strap (JRPA023). The eye hook is precisely positioned (see Section 3.2)

so that the transmitter will be perfectly balanced when a neck strap is used.

## 4. NER-600 RECEIVER

### 4.1 RECEIVER FEATURES

- Patented ABC&W noise rejection system for increased interference protection
- Compact, lightweight design provides easy installation into most model designs
- State-of-the-art surface mount technology (SMT)

### 4.2 RECEIVER LAYOUT

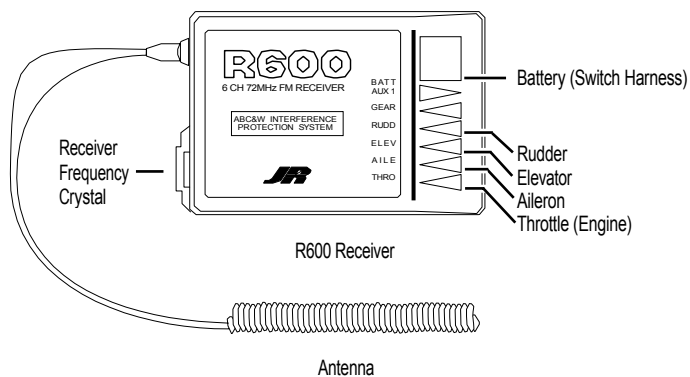

### 4.3 RECEIVER SPECIFICATIONS

<b>Model Number</b>	NER-600	<b>Selectivity</b>	8KHz/50db
<b>Type</b>	6-Channel FM ABC&W	<b>Weight</b>	1 oz.
<b>Frequency</b>	72MHz	<b>Size (W x L x H)</b>	1.43" x 2.06" x .55"
<b>Sensitivity (Microseconds)</b>	5ms Minimum	<b>Receiver Antenna</b>	39" for all Aircraft Frequencies

## 5. 577 SERVO

### 5.1 SERVO FEATURES

- A zero deadband amplifier ensures accurate neutral centering
- Low current drain
  - An indirect drive feedback potentiometer gives additional protection from vibration
- State-of-the-art surface mount technology (SMT)
- A 3-pole ferrite cored motor for reliability
- Wide speed output shaft bushings for increased precision

### 5.2 SERVO LAYOUT

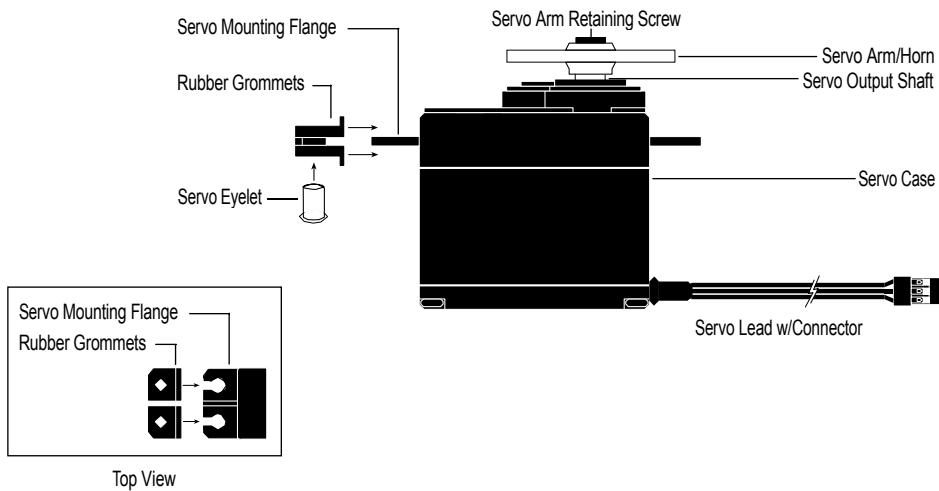

### 5.3 577 SERVO SPECIFICATIONS

<b>Torque (oz/in)</b>	43 oz.	<b>Size (WxLxH)</b>	0.73" x 1.52" x 1.32"
<b>Speed (sec./60°)</b>	.25 sec/60°	<b>Motor</b>	3-Pole Ferrite
<b>Weight (oz.)</b>	1.47		

## 6. AIRBORNE (RECEIVER) BATTERY PACK

<b>Model Number</b>	4N600	<b>Size (WxLxH)</b>	2.24" x .59" x 2.05"
<b>Voltage</b>	1.2V x 4 NiCad (4.8V 600mAh)	<b>Weight (oz.)</b>	3.3

## 7. CHARGER SPECIFICATIONS

<b>Model Number</b>	NEC-221	<b>Output Current</b>	50mAh Transmitter/ 50mAh Receiver
<b>Input Voltage AC</b>	100-120V	<b>Charging Time</b>	15 Hours

## 8. CHARGING YOUR QUATTRO RADIO SYSTEM PRIOR TO INSTALLATION

Your Quattro Radio System is shipped from the factory with both the transmitter and receiver NiCad batteries in a discharged state. Before attempting to install/operate your Quattro System, it is important that the system be charged for approximately 24 hours to ensure that both transmitter and receiver packs are at peak capacity.

### Special note on J-line transmitter charge polarity:

The center pin of the charge receptacle on all J-line brand radio systems is Negative polarity. Therefore, the center pin on all J-line or JR chargers is negative, not positive. Your J-line radio system's charge polarity is reversed from many other manufacturers chargers. Beware of improper polarity connections based on "color code" wire leads as they DO NOT APPLY in this instance.

You must always be certain that the center pin on any charger used with this system is wired for negative polarity, otherwise damage will occur to the charge circuit of the Quattro. The J-line warranty does not cover any system that is damaged by reverse polarity charging.

Under normal conditions, subsequent recharging of your Quattro System will require only an overnight charge (approximately 16 hours) to attain peak charge capacity.

The charger supplied with this system is designed to recharge your transmitter and receiver batter packs at a rate of 50mAh.

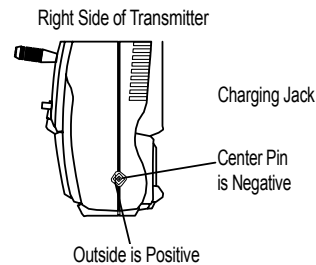

Charger Pigtail for Transmitter

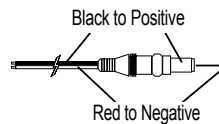

Charger Pigtail for Receiver



### 8.1

## BATTERY CHARGER

The pilot lamps on the battery charger should always be ON during the charging operation. If they are not, check to make sure you have turned off both the transmitter and receiver.

Do not use the charger for equipment other than JR. The charging plug polarity may not be the same and equipment damage may result.

Do not use other manufacturers' after-market accessories that plug into the transmitter's charging jack. If you do, any damage that results will not be covered by the warranty. If you are unsure of compatibilities with your radio, seek expert advice before doing anything to avoid possible damage. During the charging operation, the charger's temperature is slightly elevated. This is normal.

## 9. PRE-INSTALLATION SYSTEM PREPARATION

### 9.1

#### FLIGHT PACK CONNECTIONS

Connect all flight pack components of your Quattro System as outlined in the diagram below:

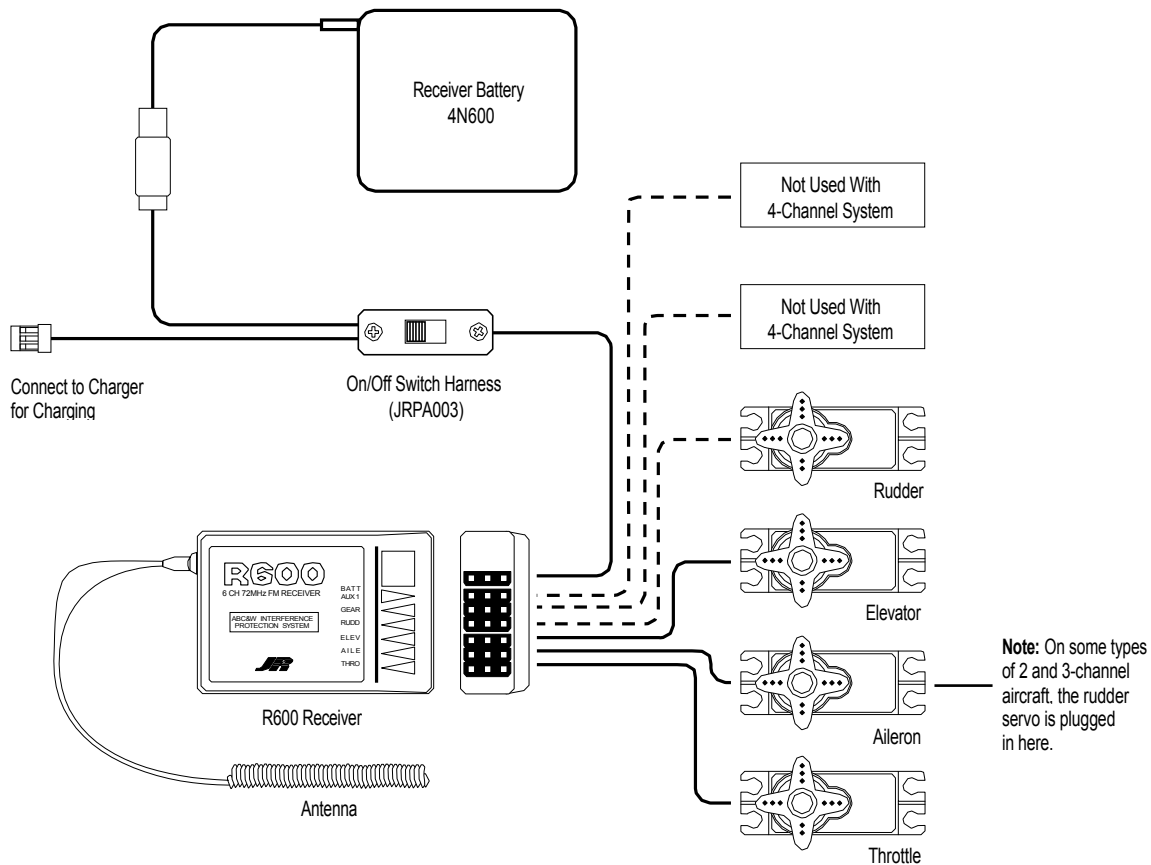

### 9.2

#### TRANSMITTER PREPARATION

Adjust each of the 4 trim levers (aileron, elevator, rudder, and throttle) to the center position.

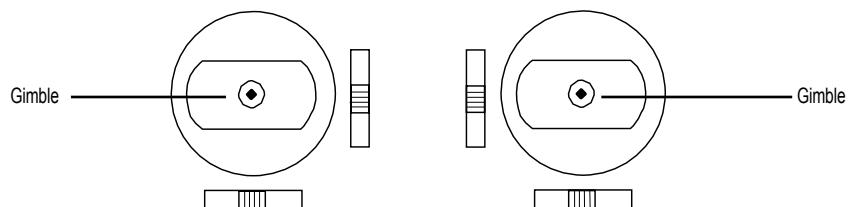

## 9.3

### 577 SERVO PREPARATION

Using a Phillips screwdriver, remove the servo arm retaining screws from each of the 577 servos as shown in Figure 1. Next, install 4 servo grommets and 4 servo eyelets to each 577 servo as shown in Figure 2.

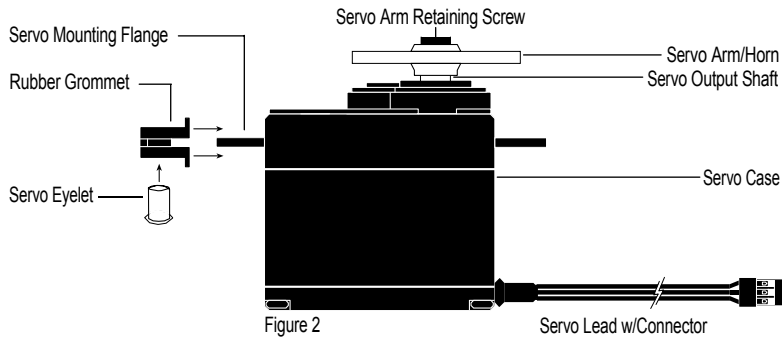
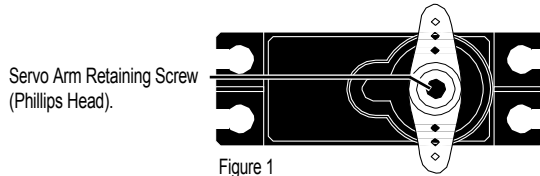

## 9.4

### SYSTEM CHECK

Slide the power ON/OFF switch on your Quattro Transmitter to the "ON" position.

Next, slide the ON/OFF switch on your flight pack switch harness to the "ON" position.

By moving each of the two transmitter sticks in a fore-aft, left-right motion, the corresponding throttle, rudder, elevator, and aileron (optional) servo arm/wheel will rotate. Please refer to the transmitter stick function chart below.



With the system still activated (ON), move the throttle stick to the neutral (center) position. Double check to be sure that the four transmitter trim levers are still in their neutral position.

Next, with the power still activated to the transmitter and flight pack, remove the servo arm/horn from each of the 577 servos. Then, turn

the power "OFF" to the flight pack first, then the transmitter. By doing this, the 577 servos will be left in their neutral position, and they are now ready to be installed into your model.

**NOTE:** Save the servo arms/horns; they will be reattached to the servos after installation.

## 10. FLIGHT PACK INSTALLATION

Flight pack installation varies greatly from one model to another. For your convenience, we have included the photograph below outlining a typical

flight pack installation in a standard 4-channel trainer type model airplane.



Fuselage Servo, Receiver, Battery Installation

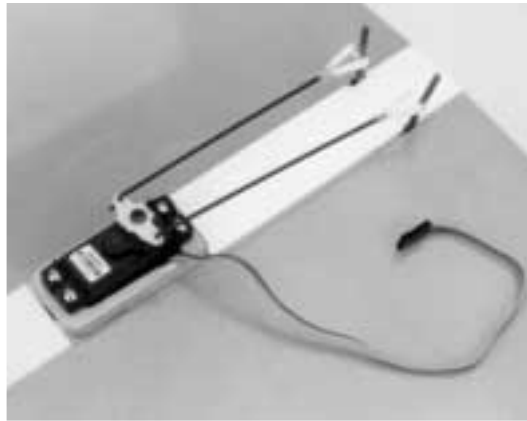

Aileron (Wing) Servo Installation

### 10.1 INSTALLATION SUGGESTIONS

It is important to correctly install the radio system in your model. Please read and carefully follow the suggestions listed below:

1. For added protection, wrap the receiver and the receiver NiCad in foam rubber that is at least 1/4" thick.
2. Run the receiver antenna through the fuselage and make sure it is fully extended. Never cut or bundle your receiver antenna — this will decrease range and performance.
3. Rubber servo grommets are included with your radio system and should be installed in the servo flanges. The servos should then be mounted on either hardwood rails or a plywood tray with the mounting screws provided. Do not overtighten the mounting screws. The flange of the brass eyelets should face down (toward the wood). See Section 9.3.
4. With the servo at neutral, install the required servo arm/horn exactly 90° to the servo case as shown in the diagram below.
5. Before installing the servo output arms, make sure the servo is in its neutral position.
6. All servos must be able to move freely over the full range of their travel. Make sure the linkages do not impede servo travel. A stalled servo will drain the battery pack within a few minutes.
7. In the case of gas-powered model aircraft, mount the receiver power switch on the side of the fuselage opposite the muffler to protect the switch from exhaust residue. With other types of models, mount the switch in the most convenient place. Make sure the switch operates freely and is capable of traveling its full distance.

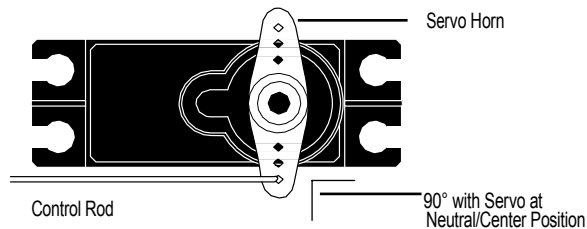

## 10.2 SERVO REVERSING

After radio installation, it is imperative that the proper servo/control system direction be established. Servo reversing allows you to alter the direction of the servo/control surface movement to

match the direction of the transmitter stick. Please refer to the chart in the following section below to determine the proper control surface direction.

## 10.3 SETTING REVERSING SWITCHES

1. Connect all control linkages and check to see that all servos move freely.
2. While standing directly behind the airplane, go through the steps shown in the charts below to check proper direction of the control surface.
3. Using the Servo Reversing Switches located behind the Transmitter Battery Pack, adjust the direction of each servo for proper operation.



Servo Reversing Switches  
(Located behind Transmitter Battery Pack)

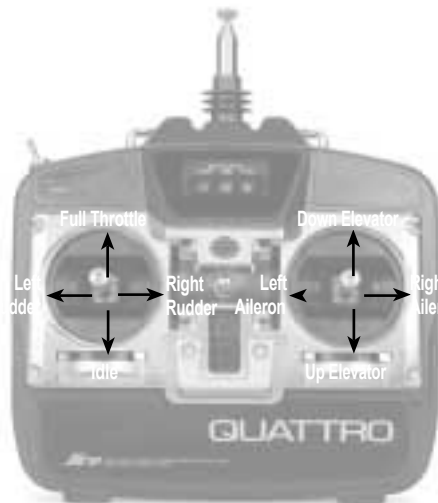

(Mode II Transmitter Shown)

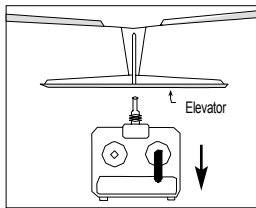

Up Elevator

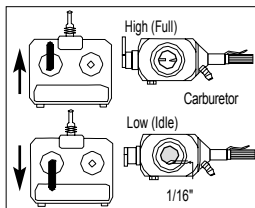

Throttle

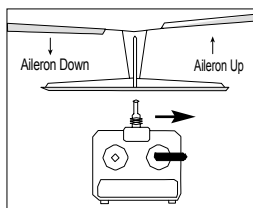

Right Aileron

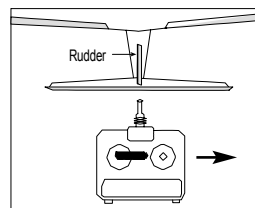

Right Rudder

## 10.4

### ADJUSTING CONTROL SURFACE TRAVEL

The final step in your flight pack installation will be to determine the amount each control surface will move on your model at full transmitter stick deflection. Please refer to your aircraft's instruction manual for suggested travel limits.

It is possible to increase/decrease the amount that your control surface moves at full stick deflection by mechanical adjustments.

It is imperative that the servo does not attempt to push/pull the control surface past its mechanical limits. This condition is called "binding." When a servo moves a control surface into a "binding"

position, the servo itself then becomes "stalled," unable to reach its full deflection. This condition is both harmful to your control linkage and to your servo. This "stalled" condition will also force the servo to drain power more quickly from your flight pack battery, thereby reducing your usable flying time. Fortunately, servo "stalling" is usually easy to detect by either a "buzzing" or "humming" sound which comes from the stalled servo.

The following diagram is designed to help clarify how to increase or decrease control surface travel mechanically to eliminate control surface "binding" and servo "stalling."

Figure 1 Normal (Linear) Linkage Set Up

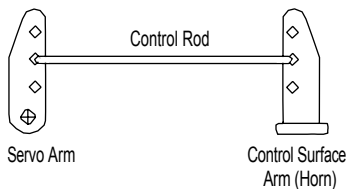

Figure 2 Increased Control Surface Movement

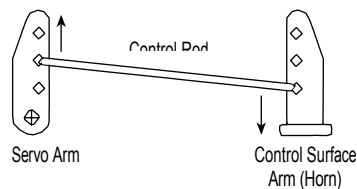
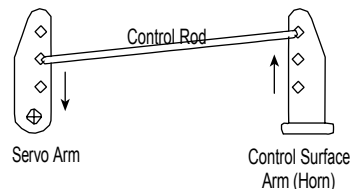

Figure 3 Reduced Control Surface Movement



To increase control surface travel, select a linkage attachment point further outward on the servo arm or further inward on the control horn closer to the control surface (Figure 2).

To reduce control surface travel, select the linkage attachment point close to the center of the servo area or further out on the control horn on the control surface (Figure 3).

Quite simply, by moving the control rod in on the servo arm/wheel, control surface travel will be

reduced, and by moving the control rod out on the servo arm, the control surface travel will be increased. The opposite holds true for the control surface arm (horn) as well. You may also use any combination of these positions to achieve proper control surface/servo travel.

**NOTE:** Once the appropriate servo arm/wheel and control rod location has been established, secure the servo arm to the servo output shaft using the original servo horn screw.

## 11. PRE-FLIGHT INFORMATION

### 11.1 QUATTRO TRAINER SYSTEM

The Quattro features a built-in trainer system. The transmitter can be used as either a master (trainer) or as a slave (trainee). The Quattro is compatible

with all other current PPM selectable (FM) J-line or JR radios that have built-in trainer systems. An optional trainer cord is needed (JRPA130).



### 11.2 OPERATING THE TRAINER SYSTEM

1. Match the servo reversing and trims of both radios.
2. Plug the optional trainer cord into both transmitters.
3. Turn ON the master transmitter.  
**NOTE:** The slave radio must be left OFF.
4. Test all the control functions on your aircraft with the master radio.
5. Push the trainer button on the master transmitter and check all the control functions with the slave radio.

**Special Note to Beginners:** We strongly suggest that you seek the help of an experienced model airplane pilot prior to flying your new model.

### 11.3 RANGE TESTING YOUR MODEL

We suggest that before the initial flight of your model, you first perform a ground range test to ensure that the transmitting/receiving abilities of your Quattro perform properly. Conduct the range test as follows:

Do not extend the transmitter antenna at this time. Turn your Quattro transmitter "ON". Next, turn the model switch "ON". Slowly walk away from the model while moving the control surfaces. The

system should function properly to a distance of approximately 60-65 feet.

**NOTE:** If your test falls short of the described range, confirm that your NiCad batteries are fully charged. If this situation remains unchanged, please contact the Horizon Service Center (address and phone number at the back of this manual) before attempting to fly your model.

## 12. GENERAL NOTES

Radio controlled models are a great source of pleasure. Unfortunately, they can also pose a potential hazard if not maintained and operated properly. It is imperative that you install your radio control system correctly. Additionally, your level of piloting competency must be high enough to ensure that you are able to control your aircraft under all conditions. If you are a newcomer to radio controlled flying, please seek help from an experience pilot or your local hobby shop.

### Safety Do's and Don'ts

- Ensure that your batteries have been properly charged prior to initial flight.
- Keep track of the time that the system is turned on so that you will have an idea of how long you can safely operate your system.
- Perform a ground range check prior to the initial flight of the day. See the "Daily Flight Checks" section for information on how to do so.
- Check all control surfaces prior to each takeoff.
- Use frequency flags.
- Do not fly your model near spectators, parking areas, or at any other area that could result in injury to people or damage of property.
- Do not fly during adverse weather conditions. Poor visibility can cause disorientation and loss of control of your aircraft. Strong winds can cause similar problems.
- Do not fly unless your frequency is clear. **Warning:** Only one transmitter at a time can operate on a given frequency. If you turn on your transmitter while someone else is operating a model on your frequency, both pilots will lose control of their models. Only one person can use a given frequency at a time. It does not matter if it is AM, FM or PCM — only one frequency at a time.
- Do not point the transmitter antenna directly toward the model. The radiation pattern from the tip of the antenna is inherently low.
- Do not take chances. If at any time during flight you observe any erratic or abnormal operation, land immediately, and do not resume flight until the cause of the problem has been ascertained and corrected.

## 13. DAILY FLIGHT CHECKS

1. Check the battery voltage on both the transmitter and the receiver battery packs. Don't fly below 9.0 volts on the transmitter or below 4.7 volts on the receiver. To do so can cause a crash of your aircraft.  
**NOTE:** When you check the receiver battery, be sure that you have polarities correct on your expanded scale voltmeter (optional).
2. Check all hardware (linkages, screws, nuts, bolts) prior to each day's flight. Be sure that binding does not occur and that everything is properly secured.
3. Ensure that all surfaces are moving in the proper manner.
4. Perform the following ground range check before each day's flying session:
  - Do not extend the transmitter antenna at this time. Turn the transmitter "ON."
  - Turn the model "ON."
  - Slowly walk away from the model while moving the control surfaces. The aircraft should function properly at a distance of 60-75 feet.
5. Ensure that all trim levers are in the proper location.
6. Check to be sure that all servo pigtails and switch harness plugs are secure in the receiver. Also, make sure that the switch harness moves completely in both directions.

## 14. WARRANTY AND SERVICE INFORMATION

### 14.1 WARRANTY COVERAGE

Your new equipment is warranted to the original purchaser against manufacturer defects in material and workmanship for one year from the date of purchase. During this period, Horizon Service Center will repair or replace, at our discretion, any component that is found to be factory defective at no cost to the purchaser. This warranty is limited to the original purchaser and is not transferable.

This warranty does not apply to any unit which has been improperly installed, mishandled, abused, or

damaged in a crash, or to any unit which has been repaired or altered by any unauthorized agencies. Under no circumstances will the buyer be entitled to consequential or incidental damages. This limited warranty gives you specific legal rights; you also have other rights which may vary from state to state. As with all fine electronic equipment, do not subject your unit to extreme temperatures, humidity or moisture. Do not leave it in direct sunlight for long periods of time.

### 14.2 REPAIR SERVICE INSTRUCTIONS

In the event that your equipment needs service, please follow the instructions listed below:

1. Check all ON/OFF switches to be sure they are off. This will speed the repair process of checking battery condition.
2. Return your system components only (transmitter, receiver, servos, etc.) Do not return your system installed in a model car, boat, plane, etc.
3. Use the original carton/packaging (molded foam container), or equivalent, to ship your unit. Do not use the carton itself as a shipping carton; you should package the equipment carton within a sturdy shipping container using additional packing material to safeguard against damage during transit. **Include complete name and address inside the carton, as well as clearly writing it on the outer label/return address area.** Ship your equipment fully insured and prepaid. Horizon Service Center is not responsible for any damages incurred during shipping.
4. Include detailed information explaining your operation of the equipment and problem(s) encountered. Provide an itemized list of equipment enclosed and identify any particular

area/function which may better assist our technicians in addressing your concerns. Date your correspondence, and include your name, mailing address, and **a phone number where you can be reached during the business day.**

5. Warranty Repairs. To receive warranty service you must include a legible photocopy of your original dated sales receipt to verify your proof-of-purchase date. Providing that warranty conditions have been met, your radio will be repaired without charge.
6. Normal Non-Warranty Repairs. Should your repair cost exceed 50% of the retail purchase cost, you will be provided with an estimate advising you of your options.

Within your letter, advise us of the payment method you prefer to use. Horizon Service Center accepts VISA or MasterCard. Please include your card number and expiration date.

Mail your system to:

**Horizon Service Center**  
4105 Fieldstone Road  
Champaign, Illinois 61822  
(217) 355-9511

## 15. FREQUENCY CHART

72MHz requires no special license to operate.

\* It is important that you attach the enclosed frequency ID plates/flag to your Quattro transmitter antenna.

72MHz		72MHz	
CH.NO.	FREQUENCY	CH.NO.	FREQUENCY
15	72.090	38	72.550
16	72.110	39	72.570
17	72.130	40	72.590
18	72.150	41	72.610
19	72.170	42	72.630
20	72.190	43	72.650
21	72.210	44	72.670
22	72.230	45	72.690
23	72.250	46	72.710
24	72.270	47	72.730
25	72.290	48	72.750
26	72.310	49	72.770
27	72.330	50	72.790
28	72.350	51	72.810
29	72.370	52	72.830
30	72.390	53	72.850
31	72.410	54	72.870
32	72.430	55	72.890
33	72.450	56	72.910
34	72.470	57	72.930
35	72.490	58	72.950
36	72.510	59	72.970
37	72.530	60	72.990

Note: Channels 11-14 are not available through JR.

## NOTES





MANUFACTURED BY JR REMOTE CONTROL