

The Photoelectricity Isolated Gasoline Engines Using the Remote Kill Switch V 1.3

This switch can switch your electronic ignition system and the battery connection safely. Usually, using the channel 5 switch of the receiver or other channels on your aircraft or vehicles, ships and other models, and when they lost control or in danger, it can shut down the engine immediately to stop danger.

It can also be used in other ways, like: the pull smoke control, the retractable landing gear control, the fireworks lit control, the shutter of the camera control, etc.

Introduction:

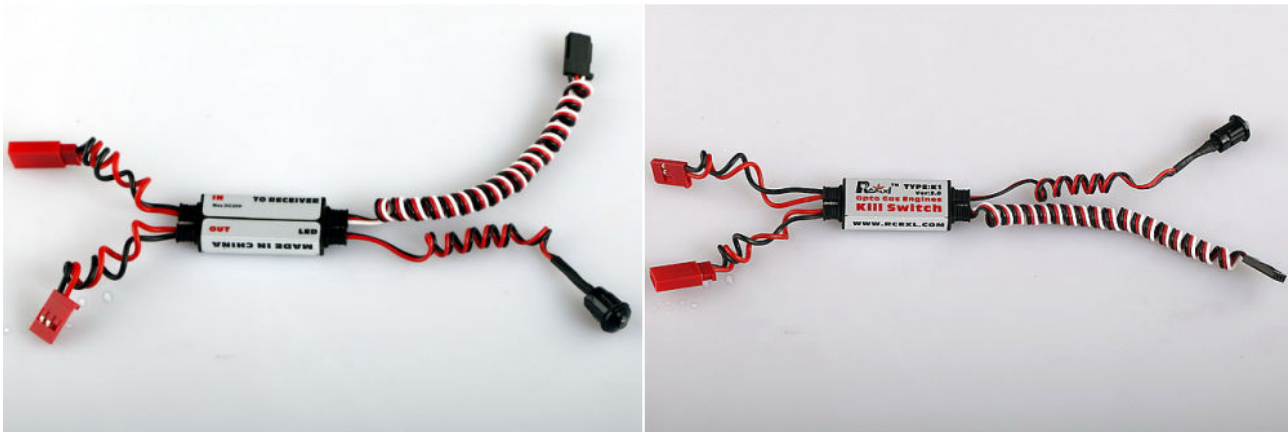

1. The high brightness prompts the luminotron has the simple install seat, and state the control status of the switch output.
2. The optical coupling isolation control signal end (from the receiver) and the controlled end (Ignition system power)
3. PIC12F675 Microchip, 8-bit microcontroller
4. The input of the controlled end supports the LI-PO/LI-ION/A123/NI-MH/NCAD and other battery, and the maximum input voltage is <math><20V</math>
5. The controlled end uses the MOS-FET(IRF7456) of 20V16A
6. The minimum 3V3A control output of the controlled end.
7. The controlled end has very low drop-side pressure below than 150mV
8. 100% surface mounting fixed
9. The input of the controlled end uses the high temperature resistant silicone wires, the standard FUTABA plug, the color is red, the line color is red and black, and the line diameter is 0.08*60
10. control signal end (from the receiver), the standard FUTABA plug, the color is black, the line color is black, red, and white, and the black is land, the red is positive, the white is signal
11. Size: L38.5mm X W17mm X L7.5mm and the weight is 11 grams.

The Characteristics of the Switch:

1. The pulse width modulation of the receiver is off at <math><1ms</math> <math><1.33ms</math>, and open at $>2ms>1.28ms$, which has no critical uncertainty of on and off. The switch is precise and stable.
2. When the receiver lost signal, the switch is off (some remote control receiver system

has the protection settings when lost control. Noted that it must be turn off, or else it can not work).

3. When the transmitter turn off the power, the switch is off (some remote control receiver system has the protection settings when lost control. Noted that it must be turn off, or else it can not work).
4. When the channel 5 of the receiver is open ($>2\text{ms}$ $>1.28\text{ms}$), turn on the power, and the status of the switch is open. When the channel 5 of the receiver is off ($<1\text{ms}$ $<1.33\text{ms}$), turn on the power, and the status of the switch is off.
5. It has the function of anti-interference. When the receiver is under strong interference, it will loss signal at once, the switch has the function of delaying off and filtering, and the delay time is 0.65 seconds, to prevent inappropriate switching from engine shutdown.
6. Support the PPM-PCM 2048 -1024 & 2.4G receiver.

Attention:

1. The controlled end of the switch does not have the function of voltage stabilization and reduction.
2. All the connecting lines must stay away from high-voltage ignition more than 30 cm.
3. The installation must be fixed firmly, and the paste additional straps are recommended.
4. Don't contact the oil or water, or the corrosive substance
5. The battery polarity of the controlled end input must not connect reversely.

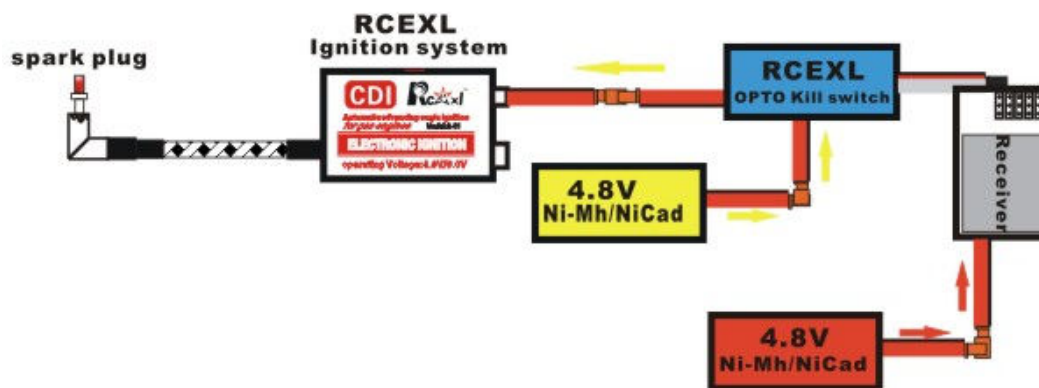

DIY to make the ignition system and the receiver share the power (not recommended, just use the engine less than 20CC, or the small-scale model aircrafts due to weight problems, have to share cells to reduce the weight of the plane)

The modification is simple, the input and output wire of the controlled end, and circuit board have five connection points, just short out two spots of the two sides, as shown on the picture.

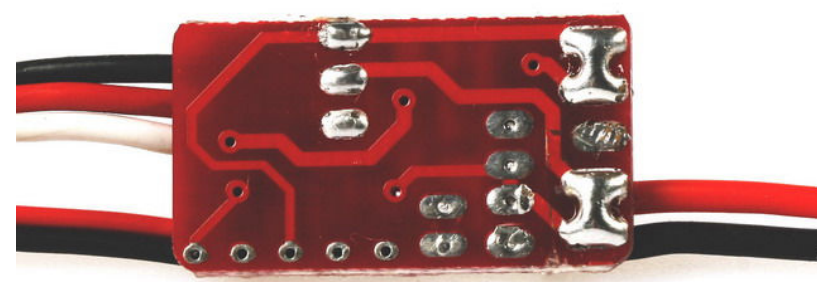
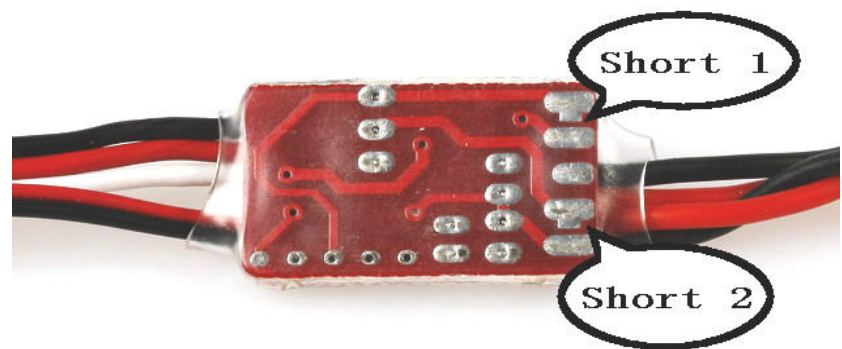
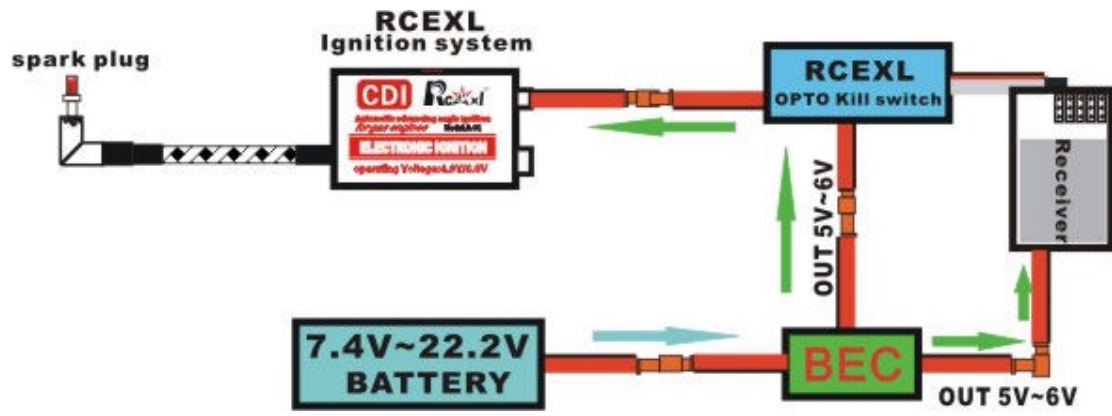

After shorted, the input controlled end is free of usage (also, you can cut off or idle. If it is idled, note that do not plug battery, or else, it will parallel with the receiver battery. If the voltage is different, it will damage the battery or receiver). At this time, the controlled output end will use the battery power of the receiver.